

- | SH NO. | TITLE |
|--------|---------------------------------------------------------------------------|
| 1) | INDEX SYMBOL KEY |
| 2) | HARNES FLOW CHART |
| 3) | +12V POWER DISTRIBUTION |
| 4) | NEGATIVE POWER DISTRIBUTION |
| 5) | +12V POWER DISTRIBUTION (OPTIONAL DISCONNECT) |
| 6) | WIPER WASHER |
| 7) | HORN |
| 8) | MANUAL FAN CONTROL |
| 9) | HVAC CLUMMINS CATERPILLAR |
| 10) | TURN SIGNAL/STOP/HAZARDS/AUX TRAILER |
| 11) | REVERSE LAMPS |
| 12) | MARKER LAMPS |
| 13) | HEAD LAMP/DRL |
| 14) | FOG LAMPS |
| 15) | FUEL HEATER |
| 16) | AIR DRYER |
| 17) | INTERFACE MODULE |
| 18) | SPOT LAMPS |
| 19) | LOAD LAMPS |
| | BRACKET MOUNTED/FLUSH MOUNTED/
MULTIPLE/COIL 10' |
| 20) | FLUORESCENT LAMP SLEEPER |
| 21) | FLOOR LAMP |
| 22) | ETHER START CATERPILLAR |
| 23) | WINDOW/LIFT |
| 24) | CENTRAL DOOR LOCKS |
| 25) | DOOR LAMPS/DOVE LAMPS |
| 26) | PREMIUM SOUND |
| 27) | SLEEPER TOOL BOX LAMPS |
| 28) | SLEEPER CLOCK |
| 29) | AUX FAN |
| 30) | SLEEPER READING LAMPS |
| 31) | REFRIGERATOR UNIT REFER |
| 32) | SLEEPER POWER ACCESS OUTLETS |
| 33) | SLEEPER FLOOR LAMP |
| 34) | SLEEPER HVAC |
| 35) | DIGITAL MESSAGE CENTER |
| 36) | ABS LOW |
| 37) | ABS HI |
| 38) | CAB CIGAR LIGHTER PAR COMM |
| 39) | SPARE SWITCHES |
| 40) | TWO SPEED INTER/FIFTH WHEEL/DIFF LOCK/PTO |
| 41) | LOW COOLANT |
| 42) | EATON TOP 2 TRANSMISSION |
| 43) | MIRROR CONTROL/HEATER |
| 44) | ENGINE BRAKE/CRUISE CONTROL/DIAGNOSTIC |
| 45) | RADIO |
| 46) | SPARE POWER SYSTEM SLEEPER |
| 47) | CATERPILLAR CLUMMINS ENGINE ECUTRS/
SPEED SENSOR/INTERUP/WARNING LAMPS |
| 48) | SVC SPEED MESSAGE CENTER |
| 49) | DATA LINK |
| 50) | CAB SPARE POWER SYSTEM EXPANSION |
| 51) | CB RADIO |
| 52) | BACKLIGHTING +12VOLTS |
| 53) | NEGATIVE SWITCH LINKS |
| 54) | SPICE LOCATION - DISTRIBUTION |
| 55) | SPICE LOCATION - DISTRIBUTION |
| 56) | ASH TRAY |
| 57) | CAB CHASSIS HARNES LAYOUT |
| 58) | SLEEPER HARNES LAYOUT |
| 59) | FUEL HOT LINE |

SYMBOL/ABBREVIATION KEY

- 1) STUD
 - 2) SPICE
 - 3) RING TERMINAL CONNECTORS
 - 4) NUMBERS EX CIRCUIT DESCRIPTION SUFFIX ALPHA
- FOR CIRCUIT NUMBER FUNCTION SEE SK06520
- 5) RED SOLID COLORS
 - RED/BLACK SOLID COLOR WITH STRIPE
 - SOLID STRIPE
 - 6) BUSS BAR
 - 7) CONNECTOR APPEARS ON MULTIPLE SHEETS
 - 8) CLC CHASSIS LOAD CENTER
 - 9) SLPR SLEEPER
 - 10) TRLR TRAILER
 - 11) MULTI CORE CABLE
 - 12) CONTINUED TO OTHER SH XX
 - 13) MOMENTARY CONTACT
 - CONTACT
 - SWITCH
 - 14) BULB

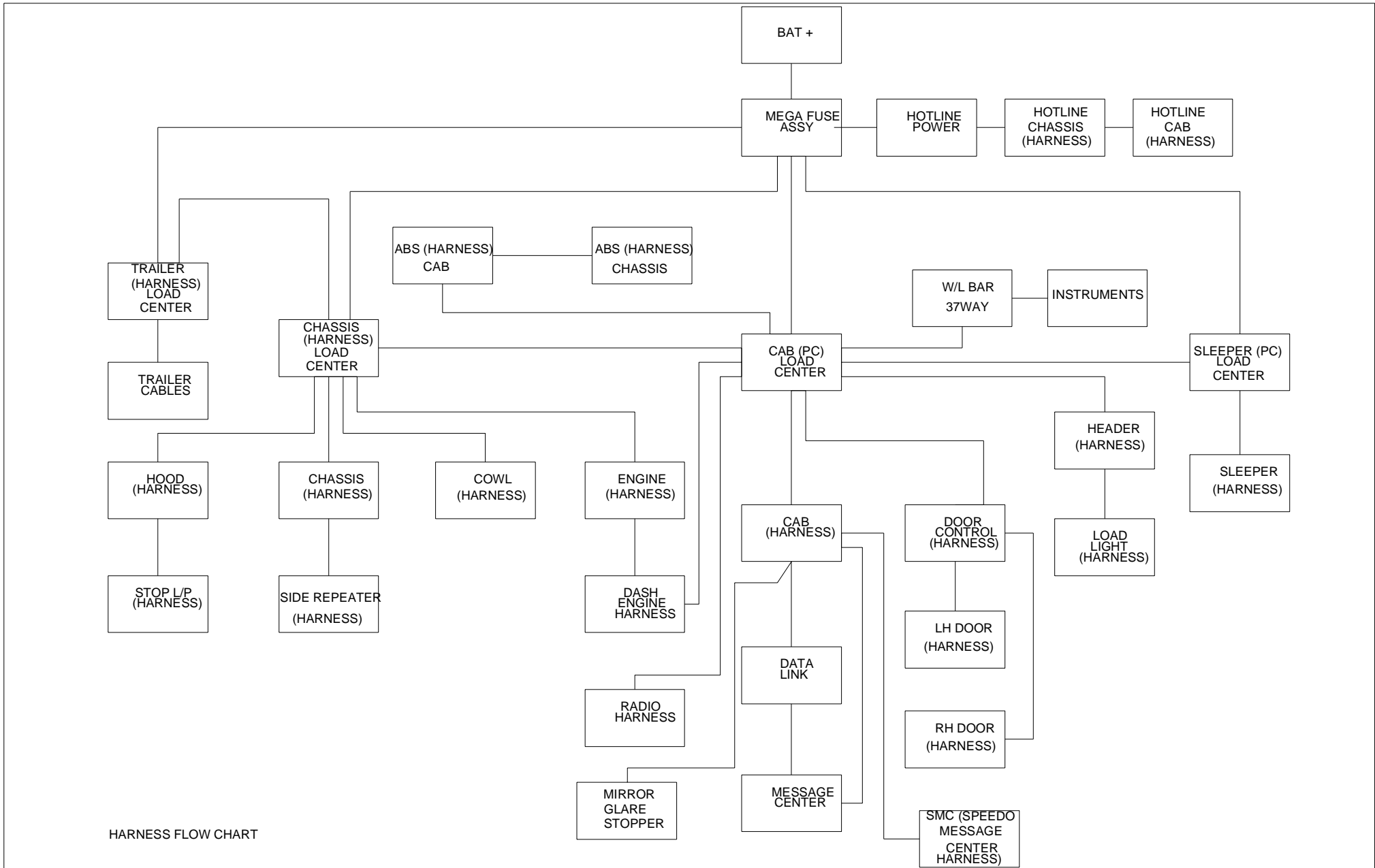

HARNES FLOW CHART



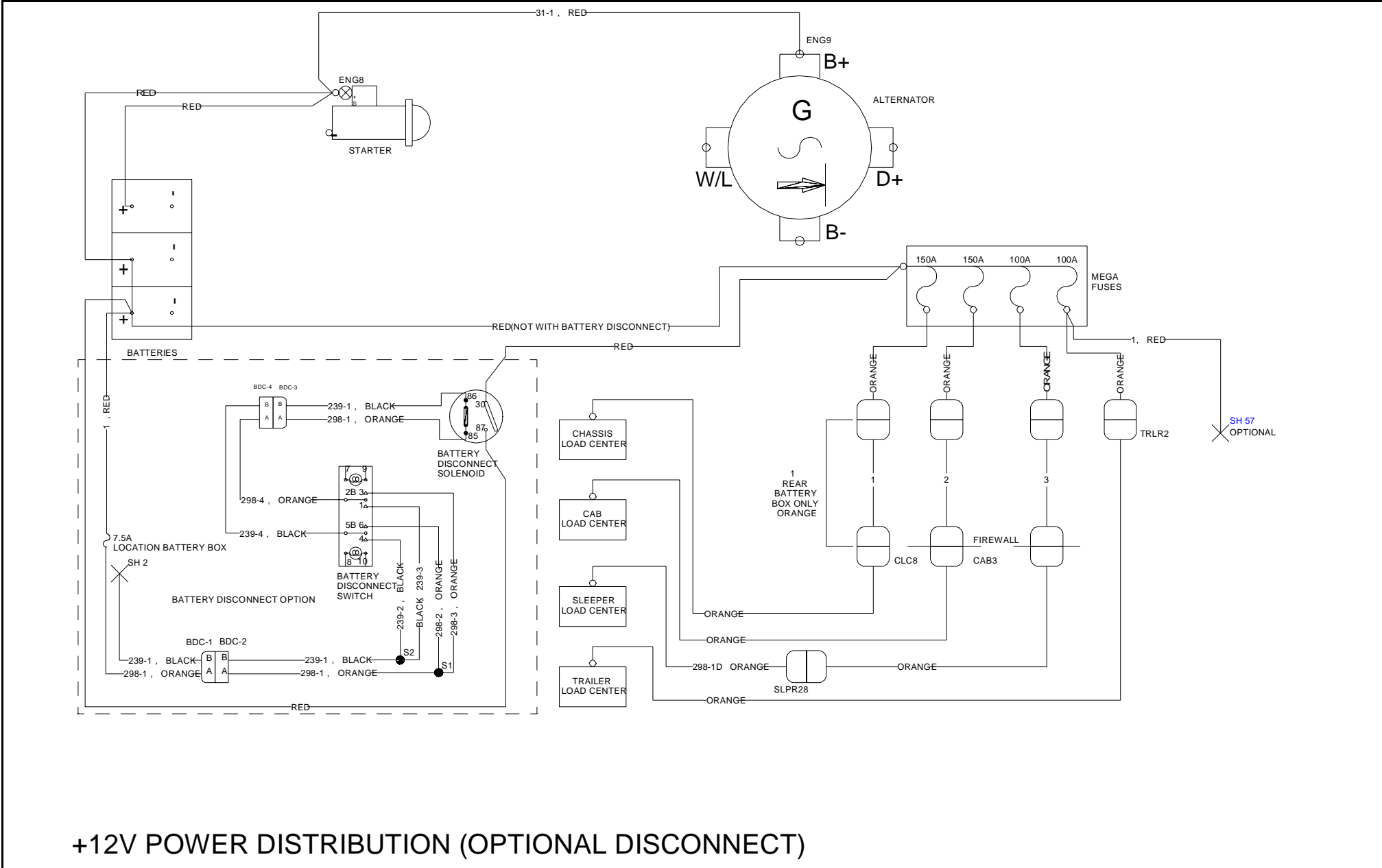

+12V POWER DISTRIBUTION (OPTIONAL DISCONNECT)



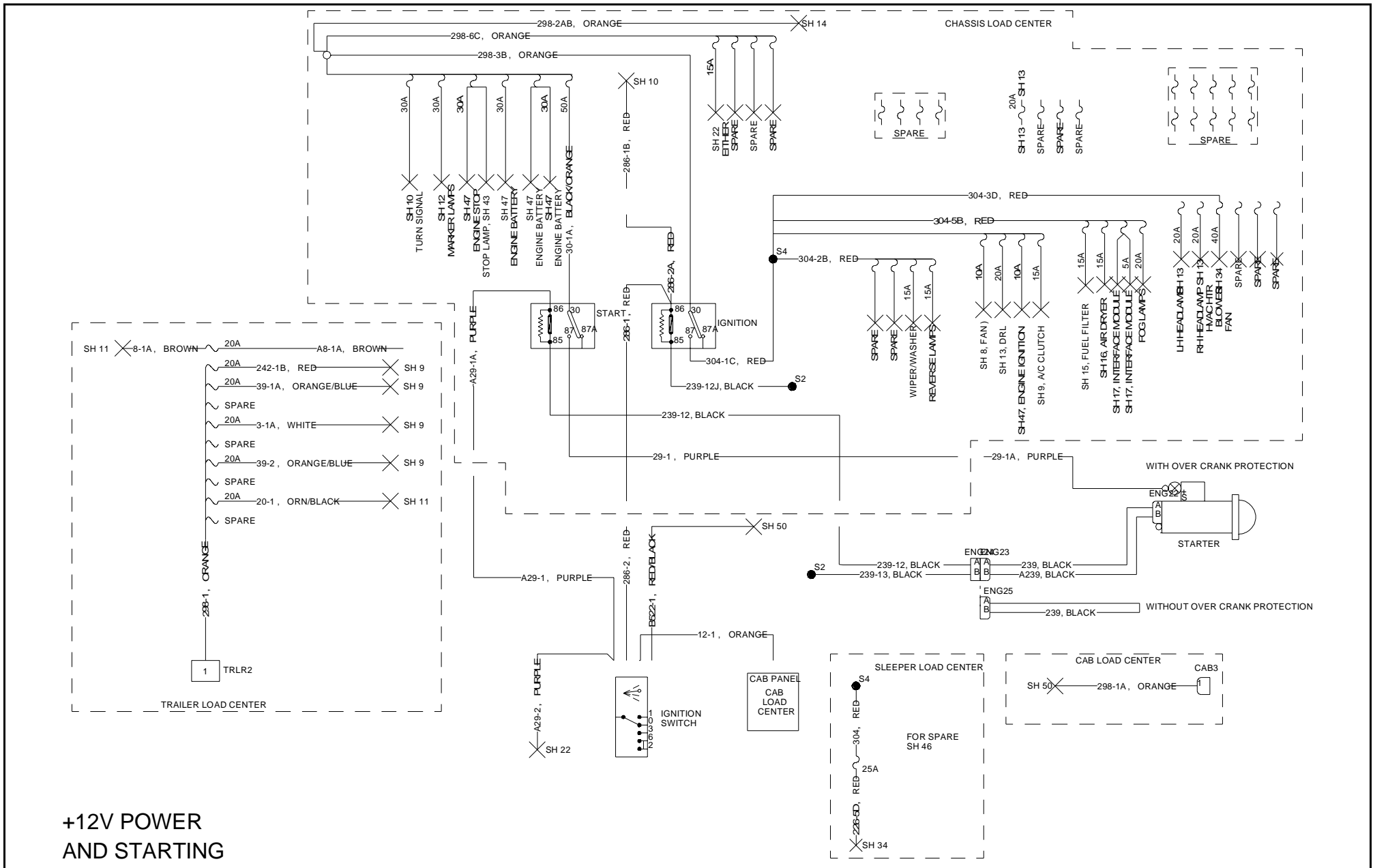

+12V POWER AND STARTING



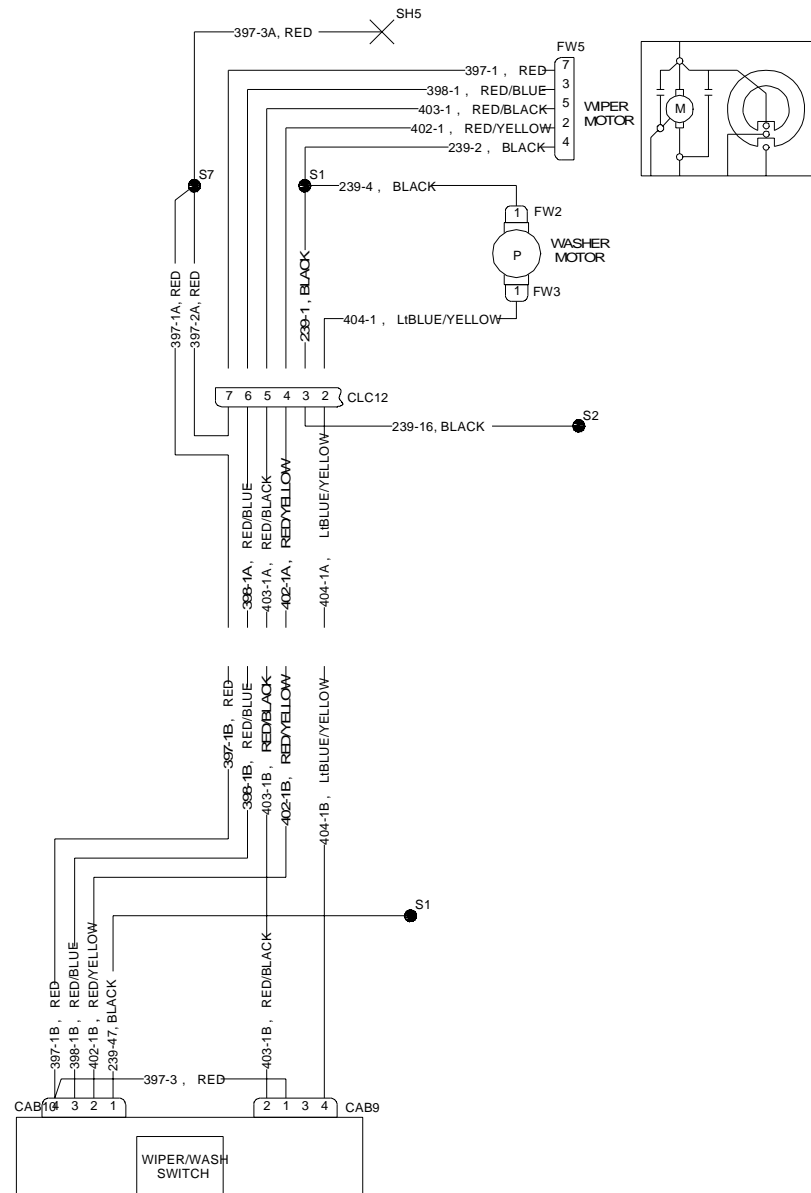

WIPER/WASHER

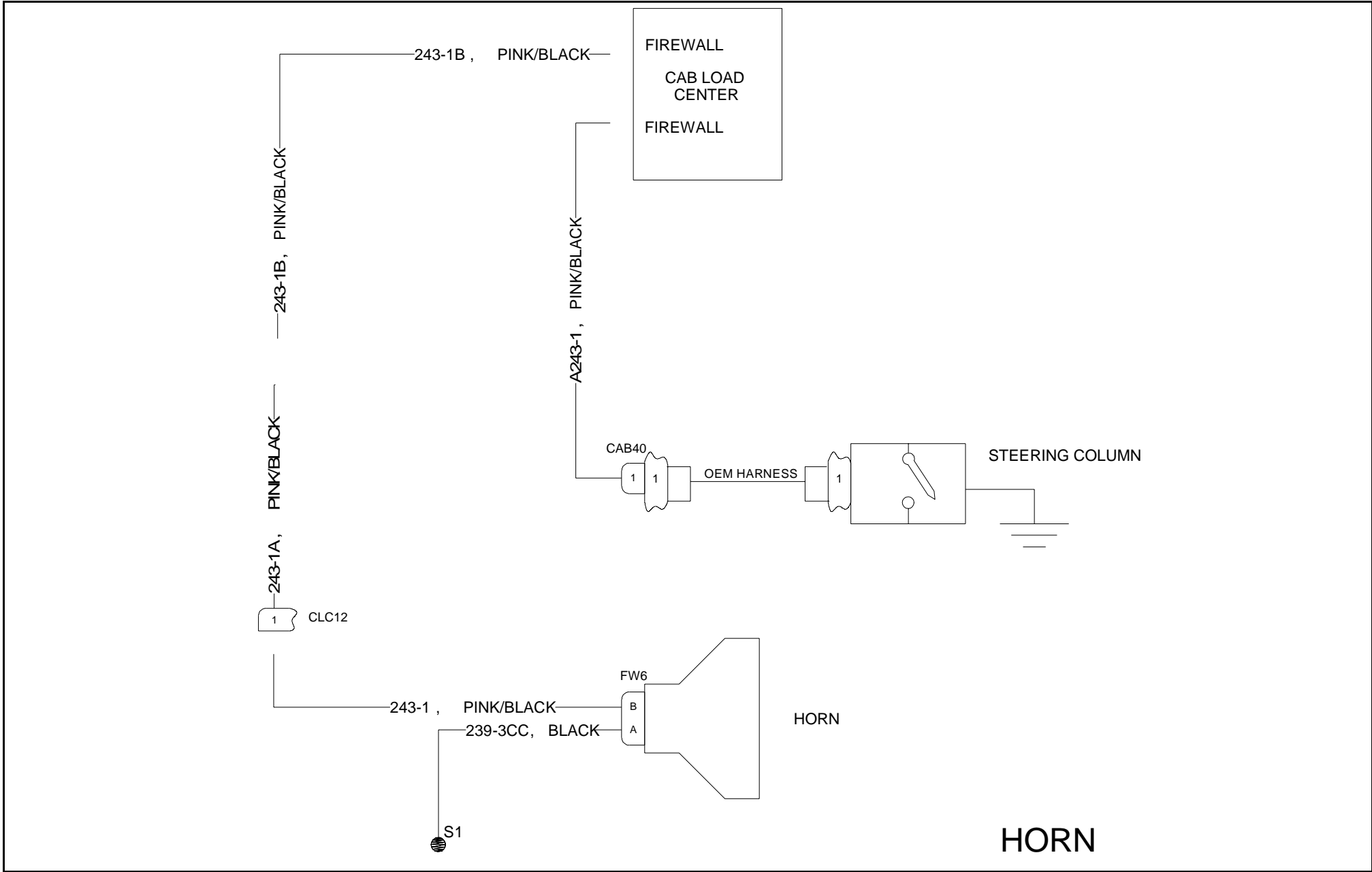

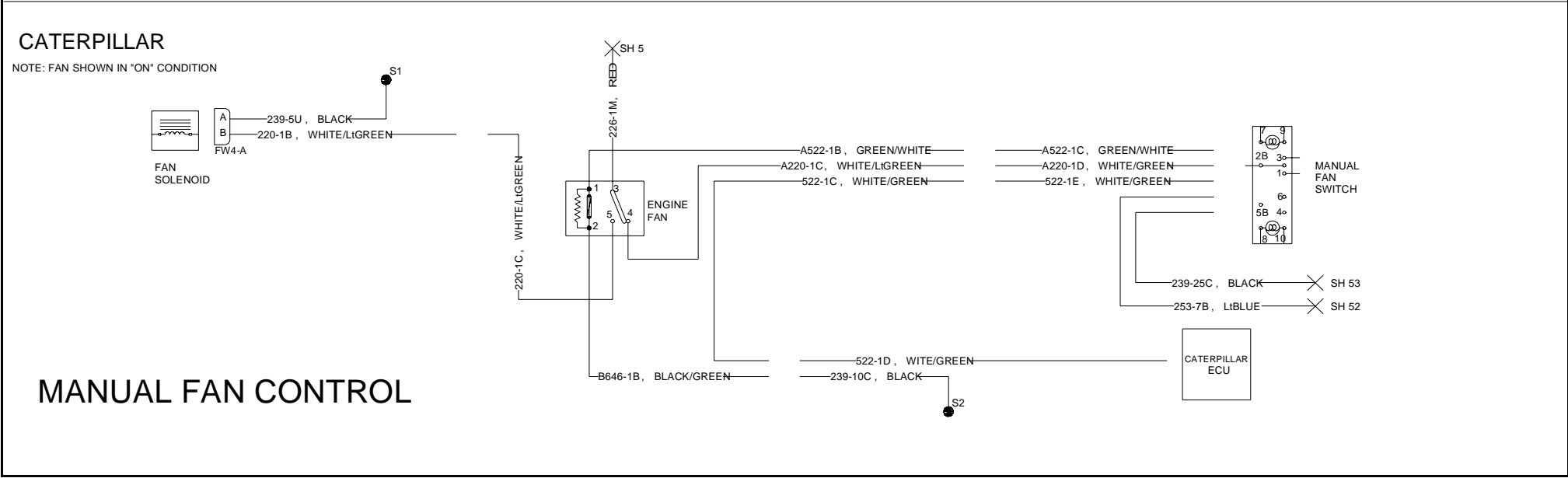
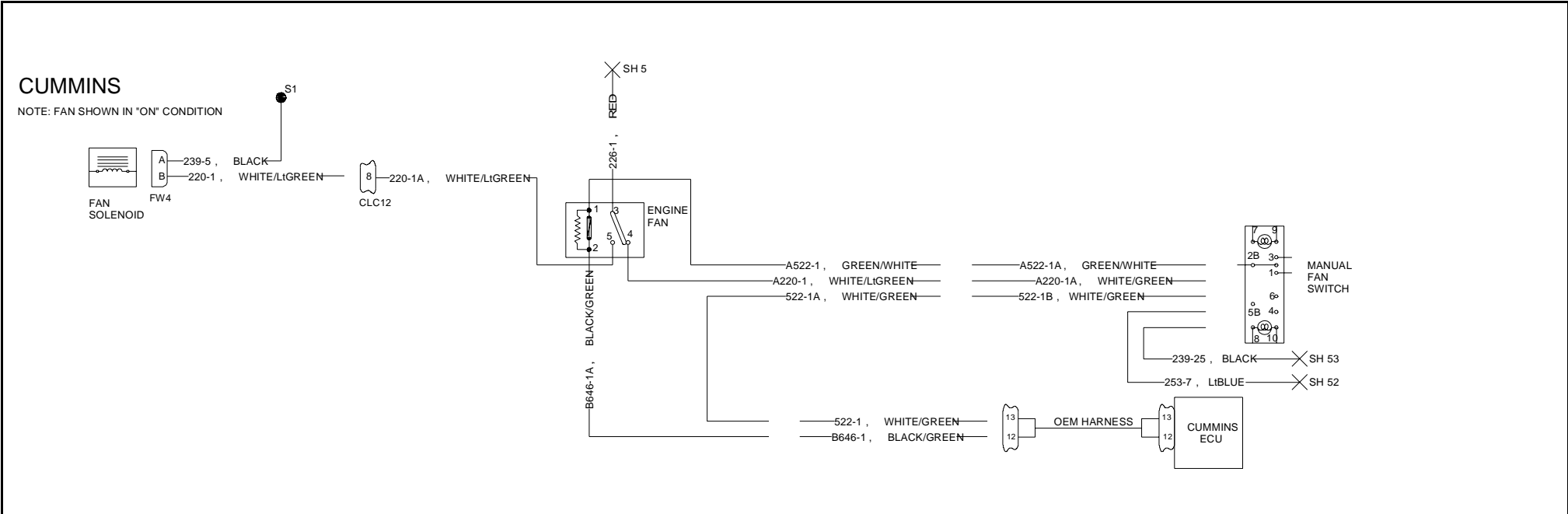

MANUAL FAN CONTROL



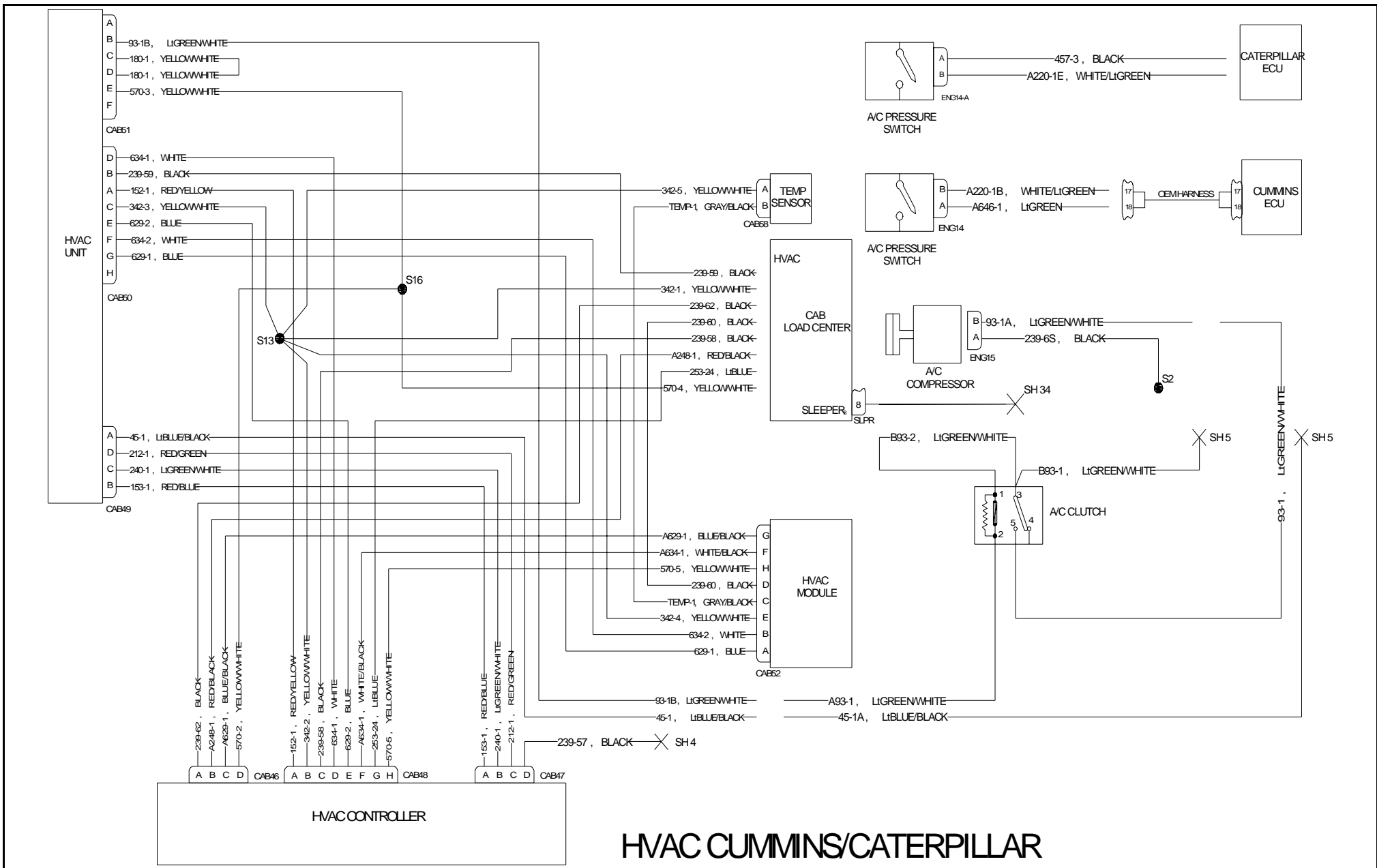

HVAC CUMMINS/CATERPILLAR

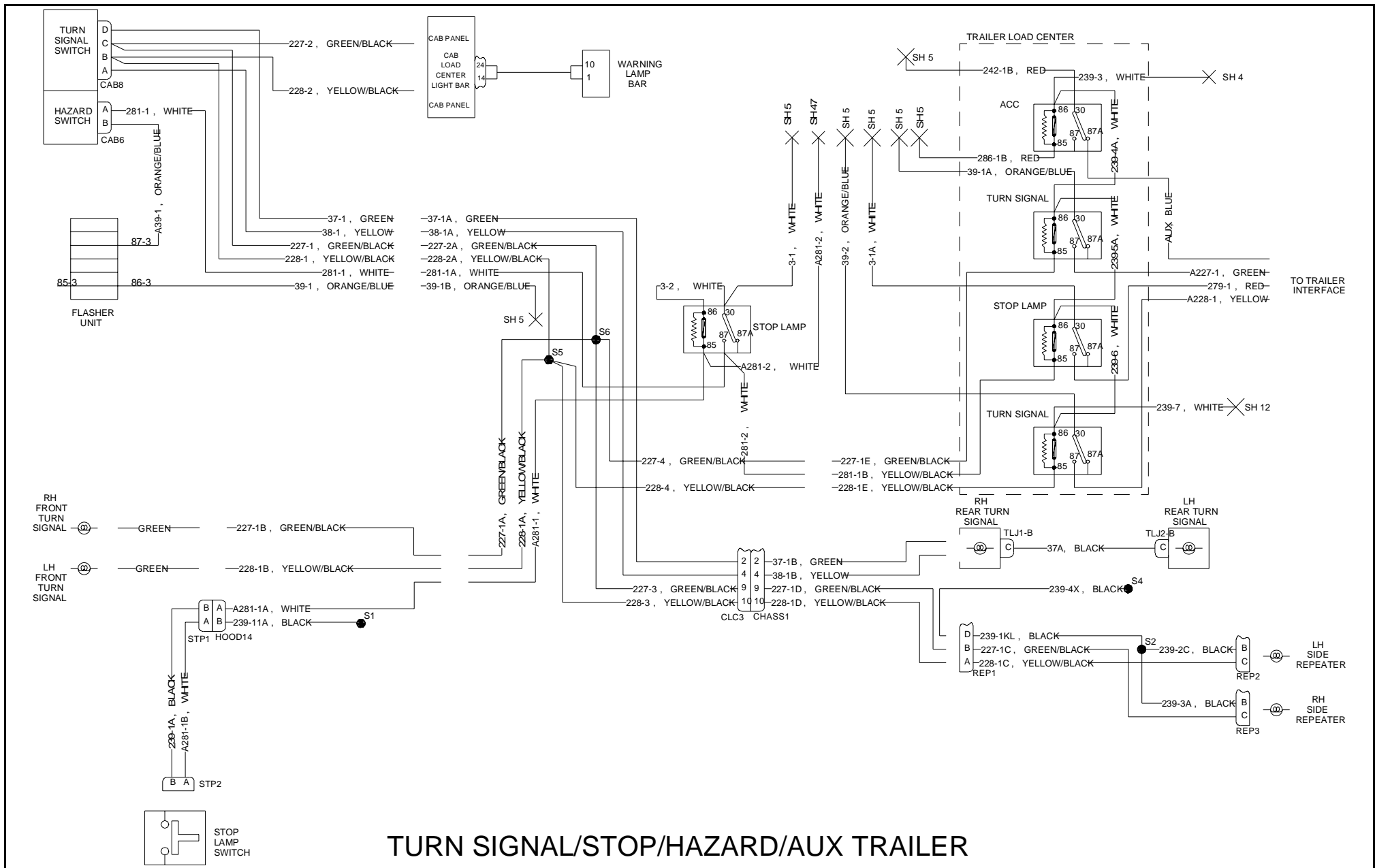

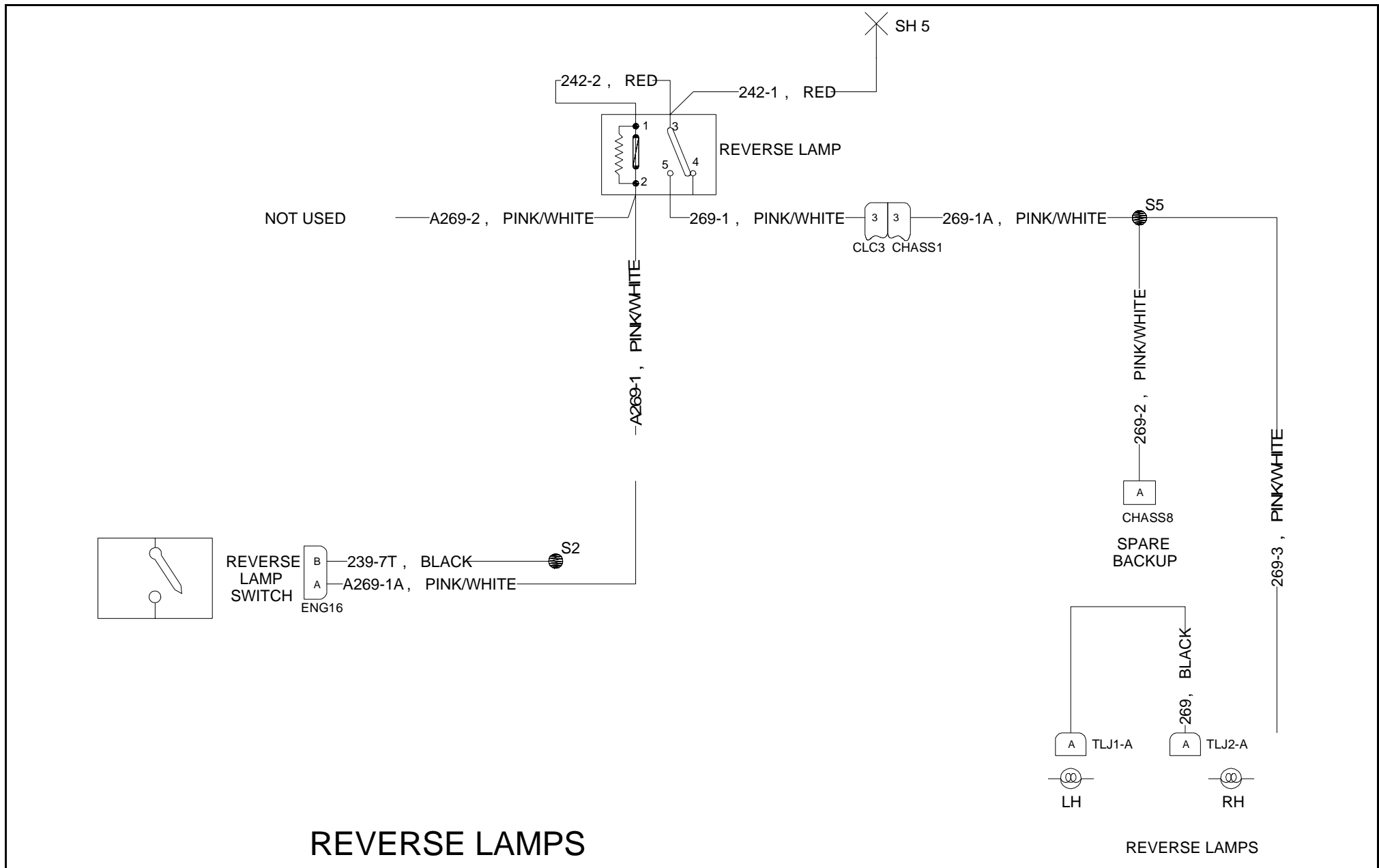

REVERSE LAMPS

REVERSE LAMPS

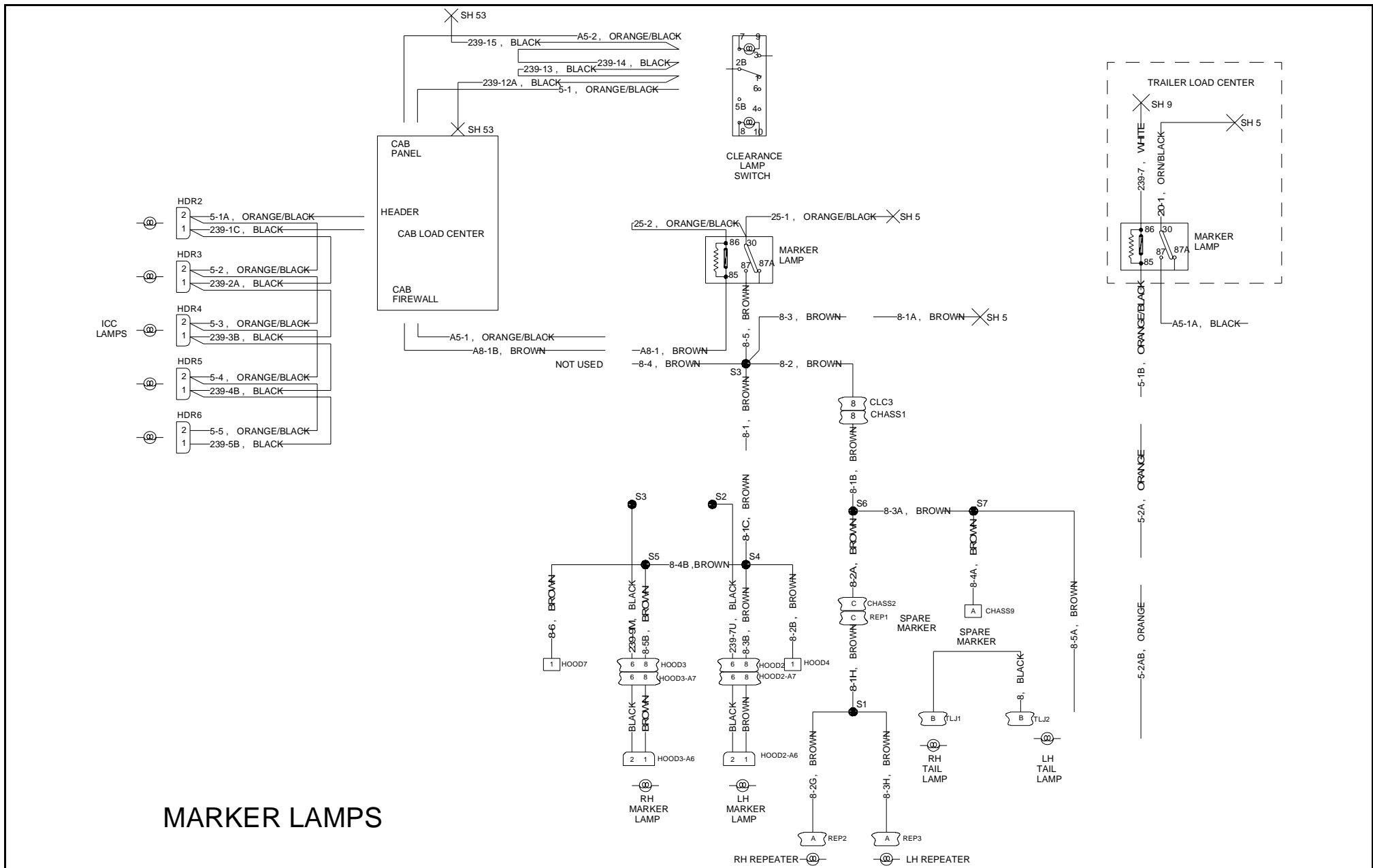

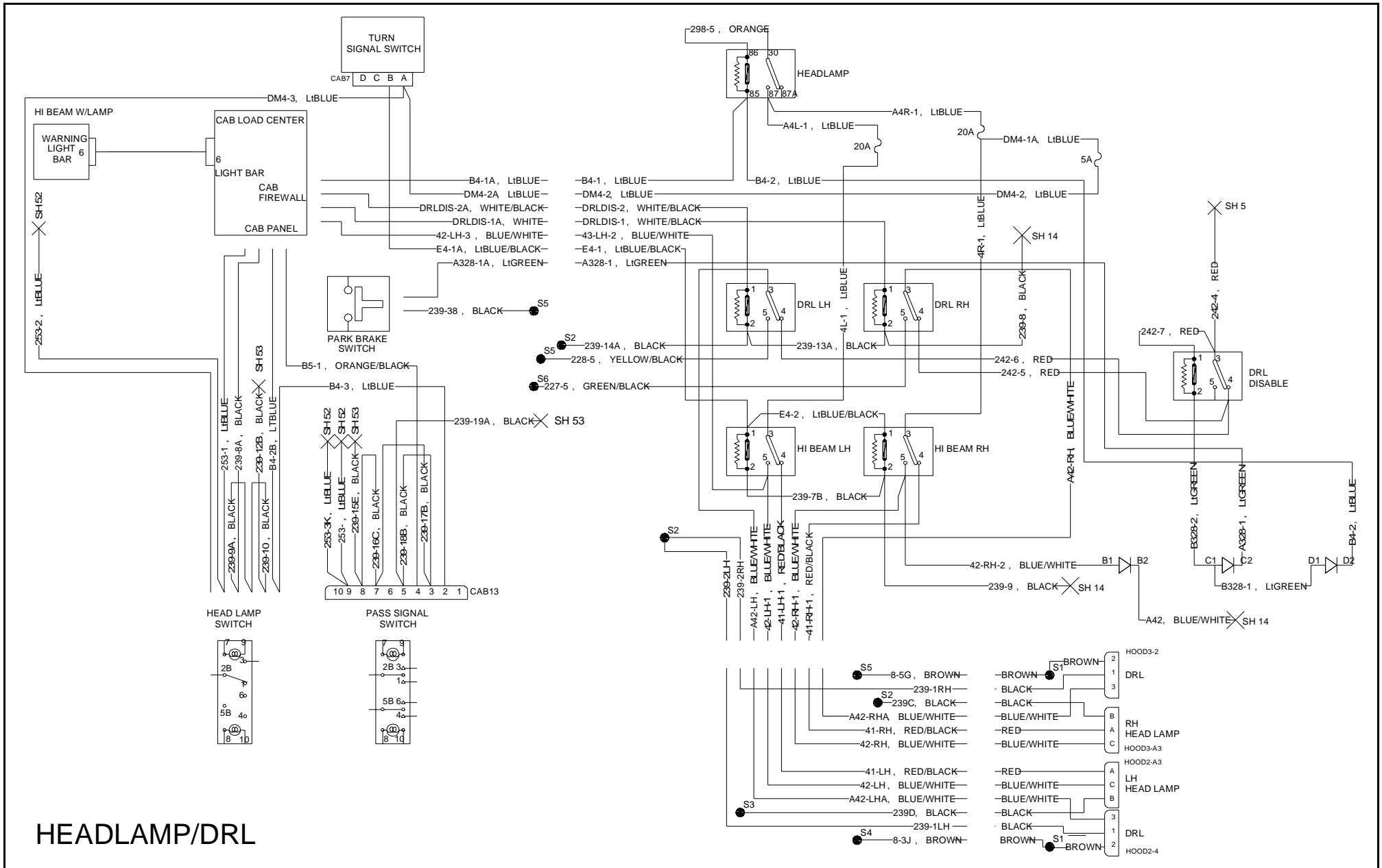

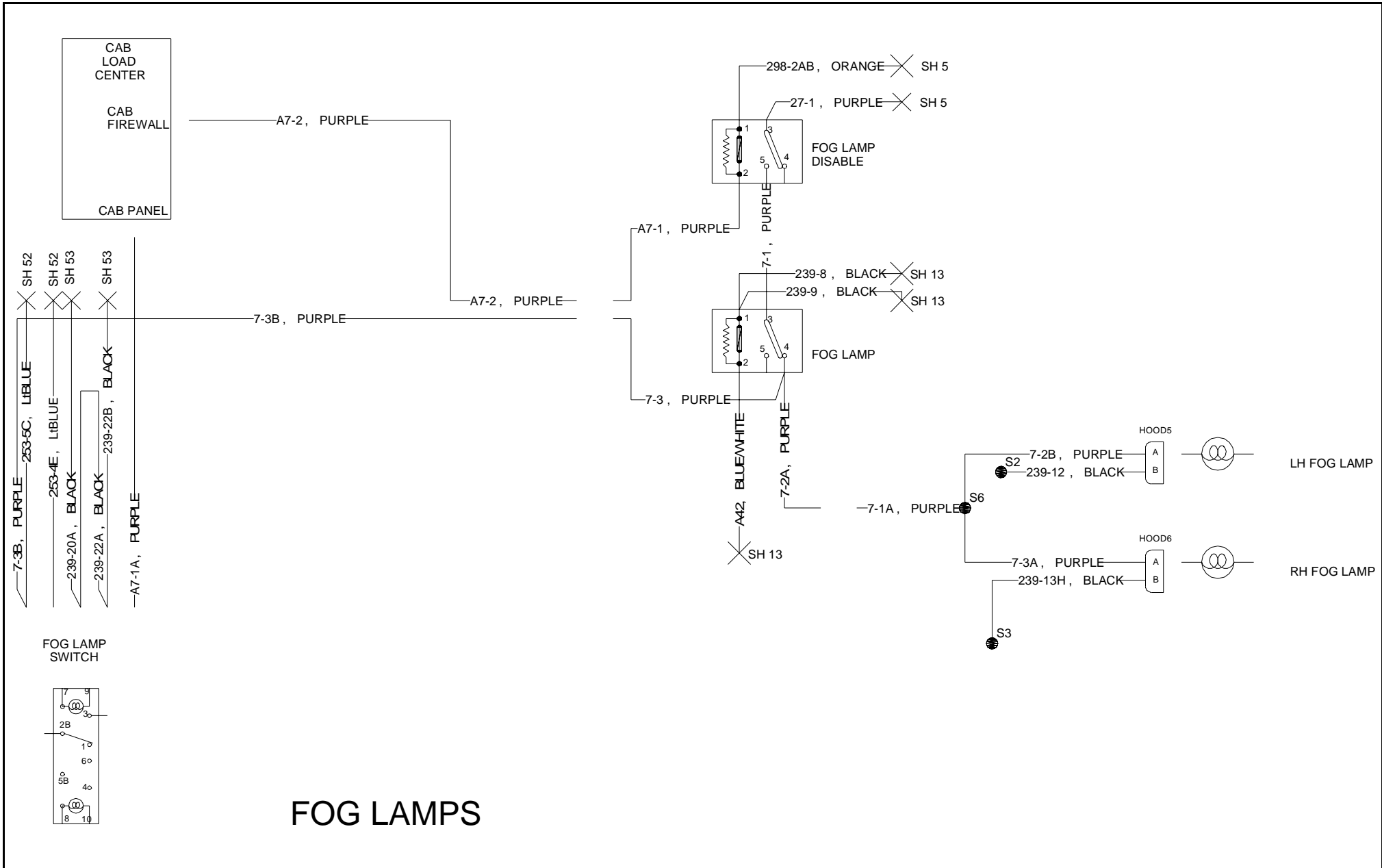

FOG LAMPS



FUEL HEATER

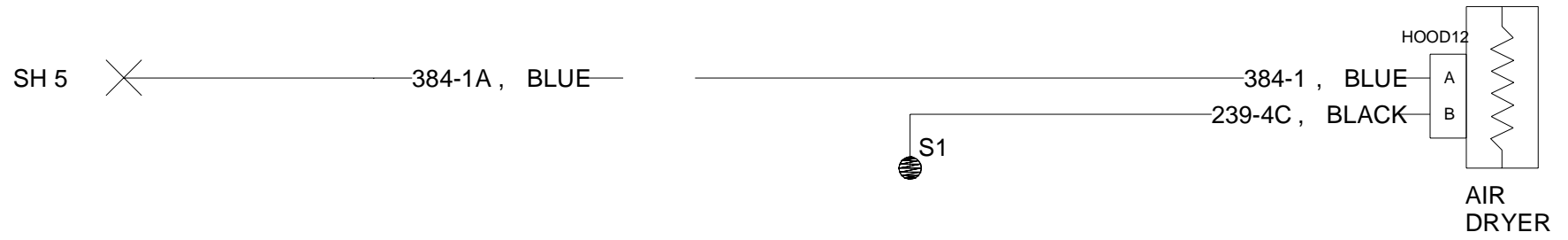

AIR DRYER

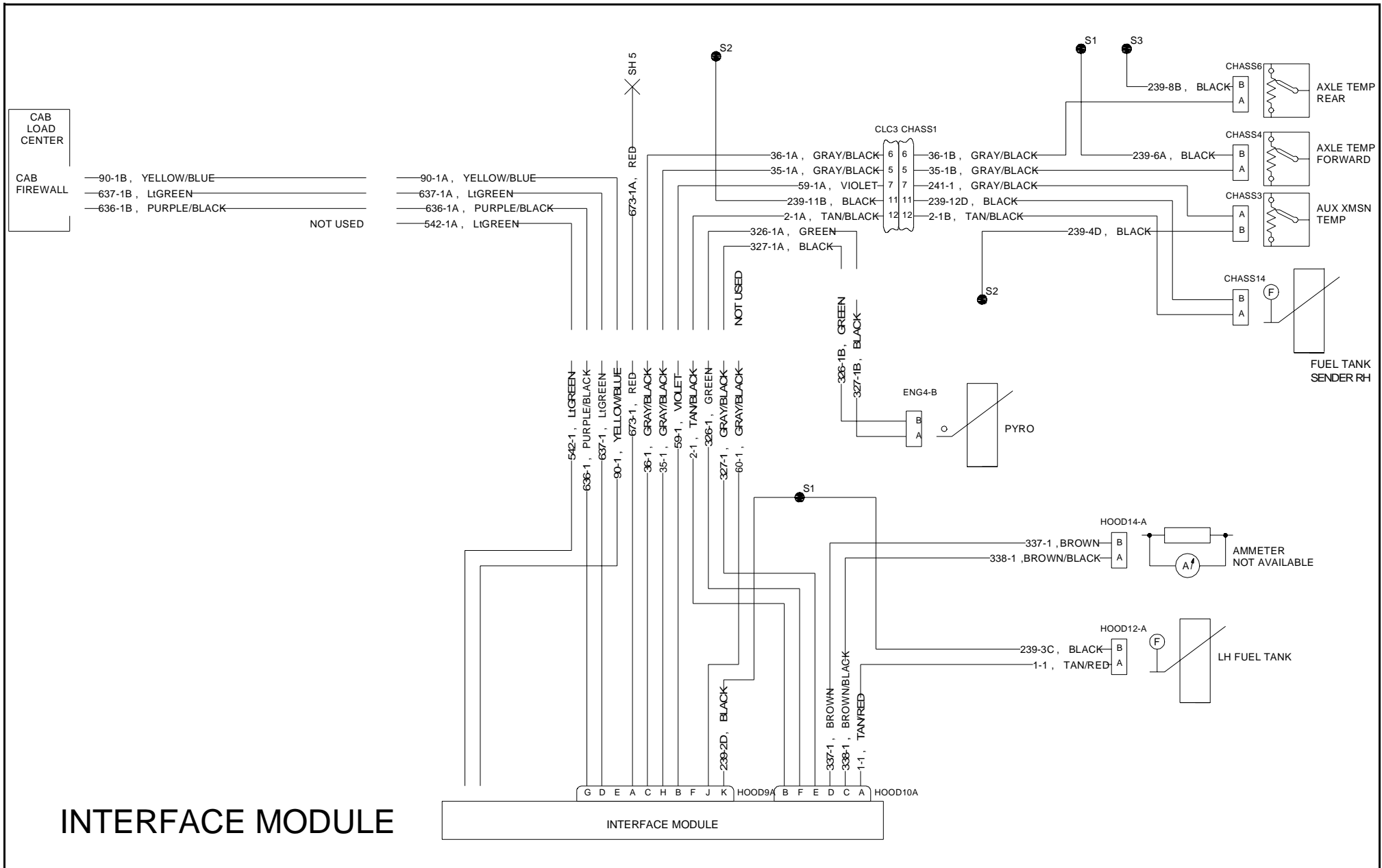

INTERFACE MODULE



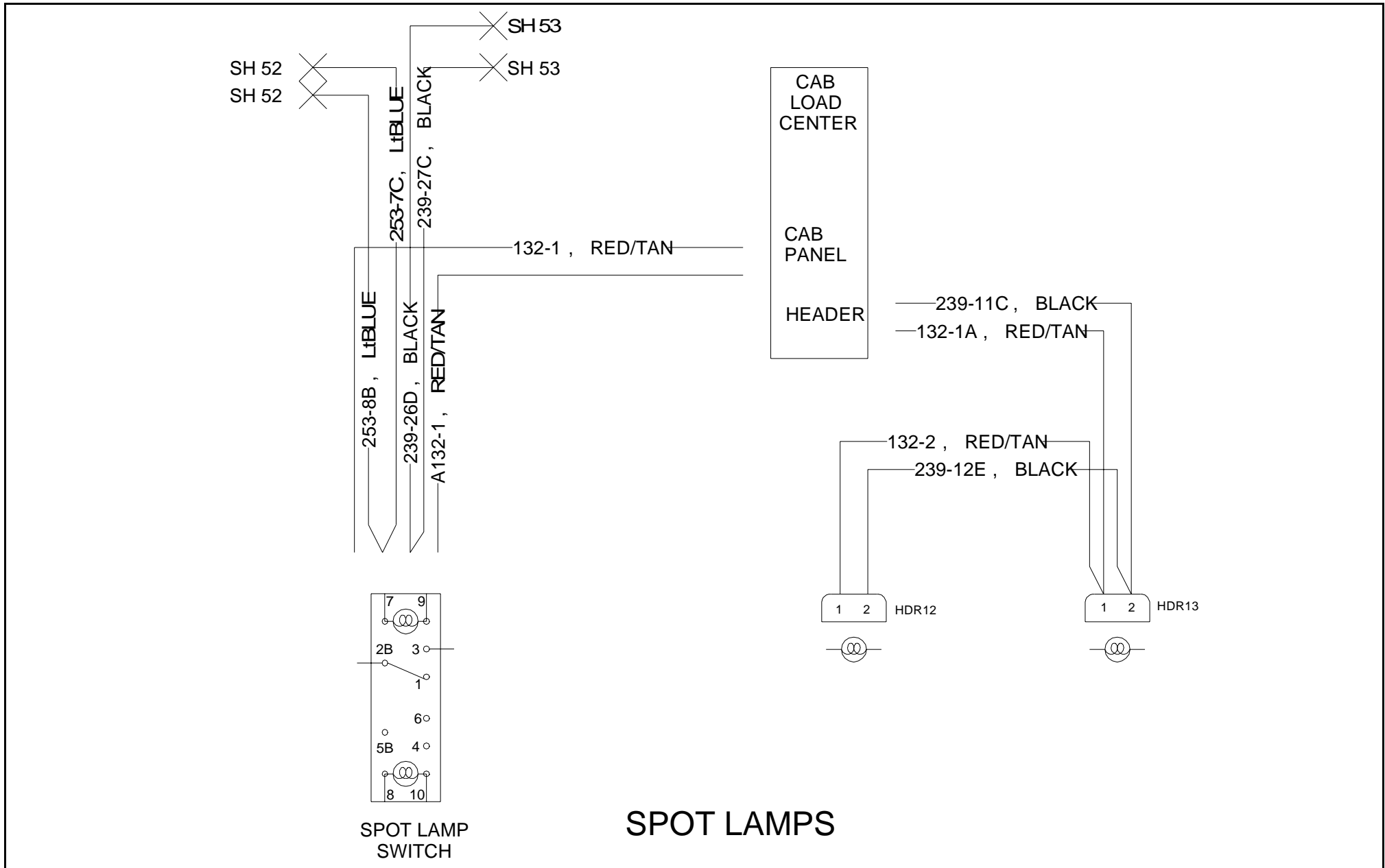

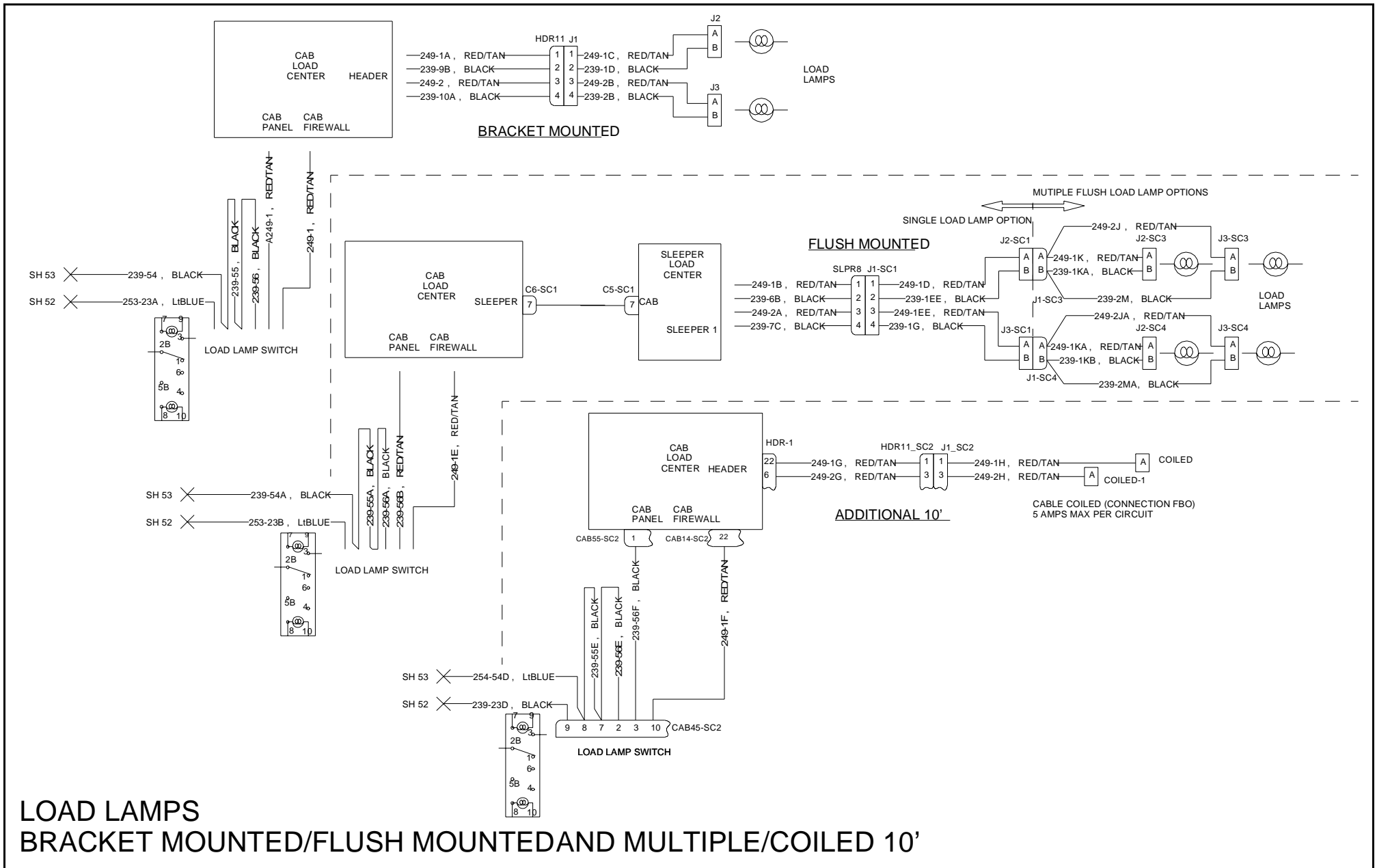

**LOAD LAMPS
BRACKET MOUNTED/FLUSH MOUNTED AND MULTIPLE/COILED 10'**



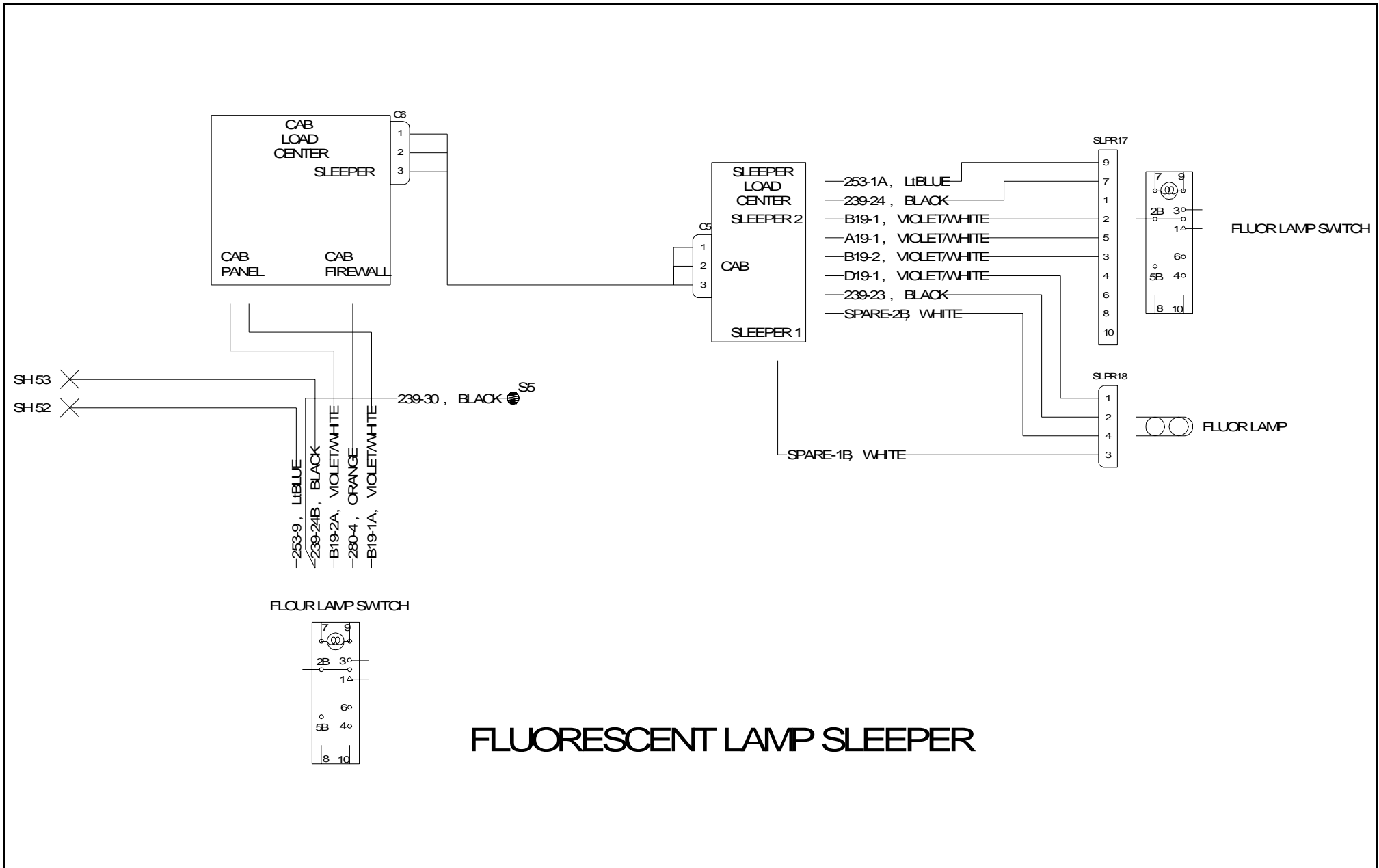

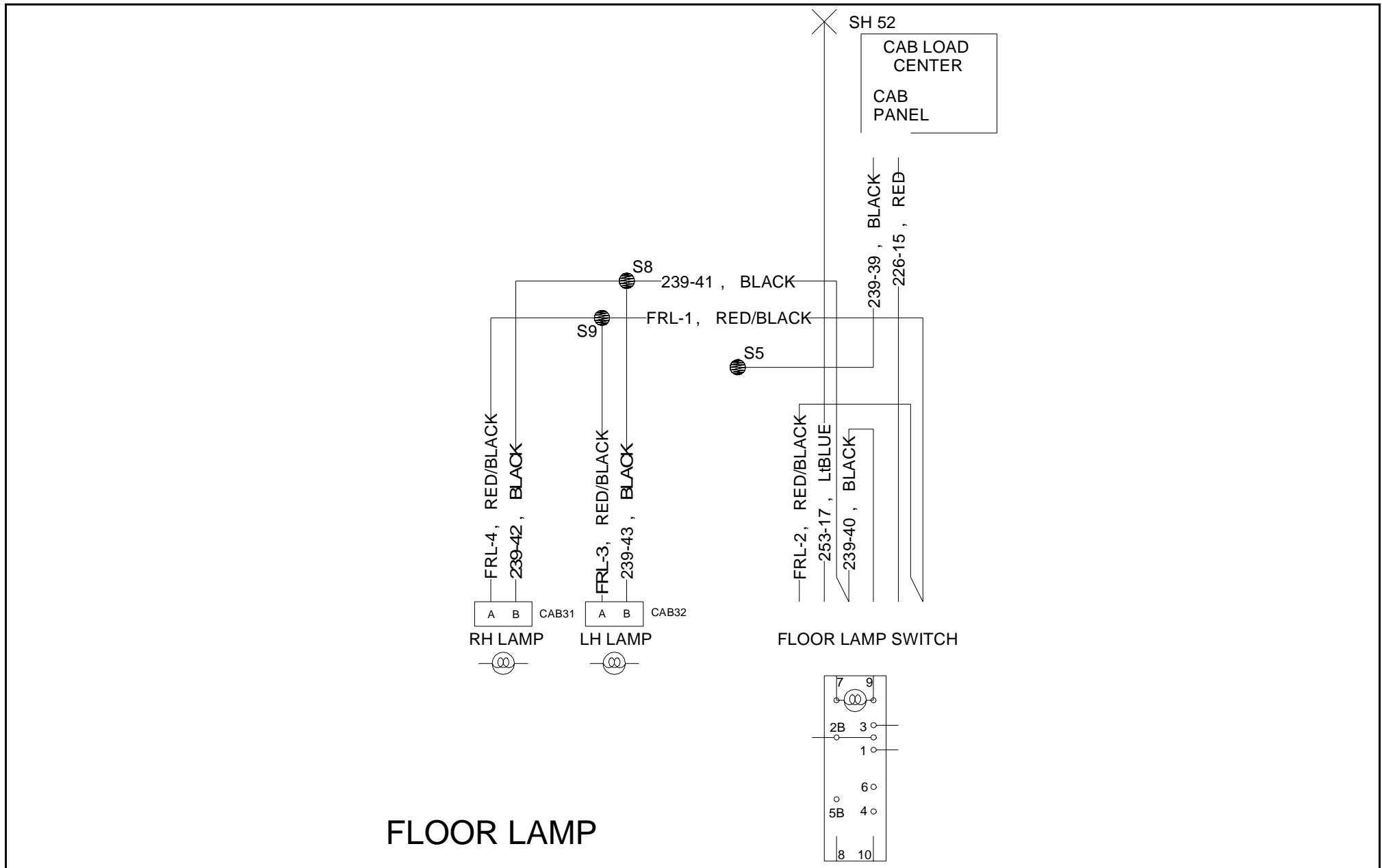

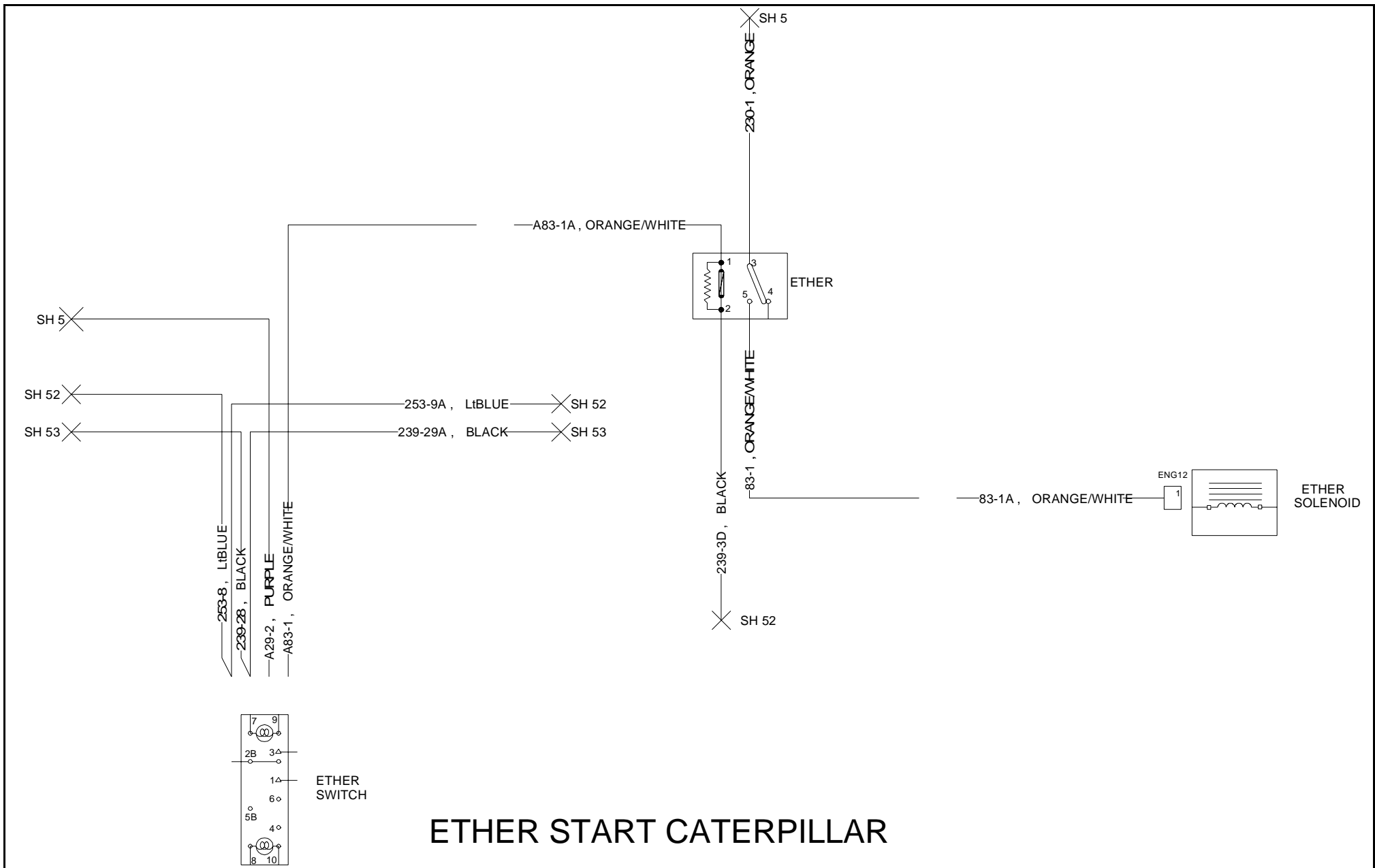

ETHER START CATERPILLAR

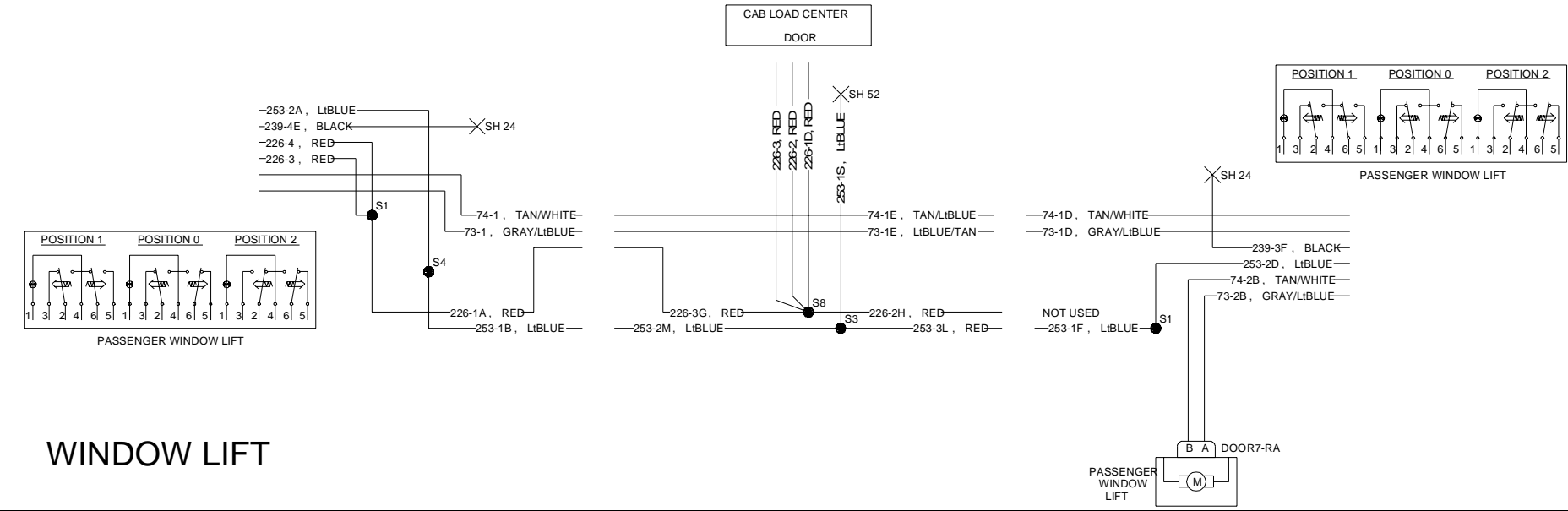
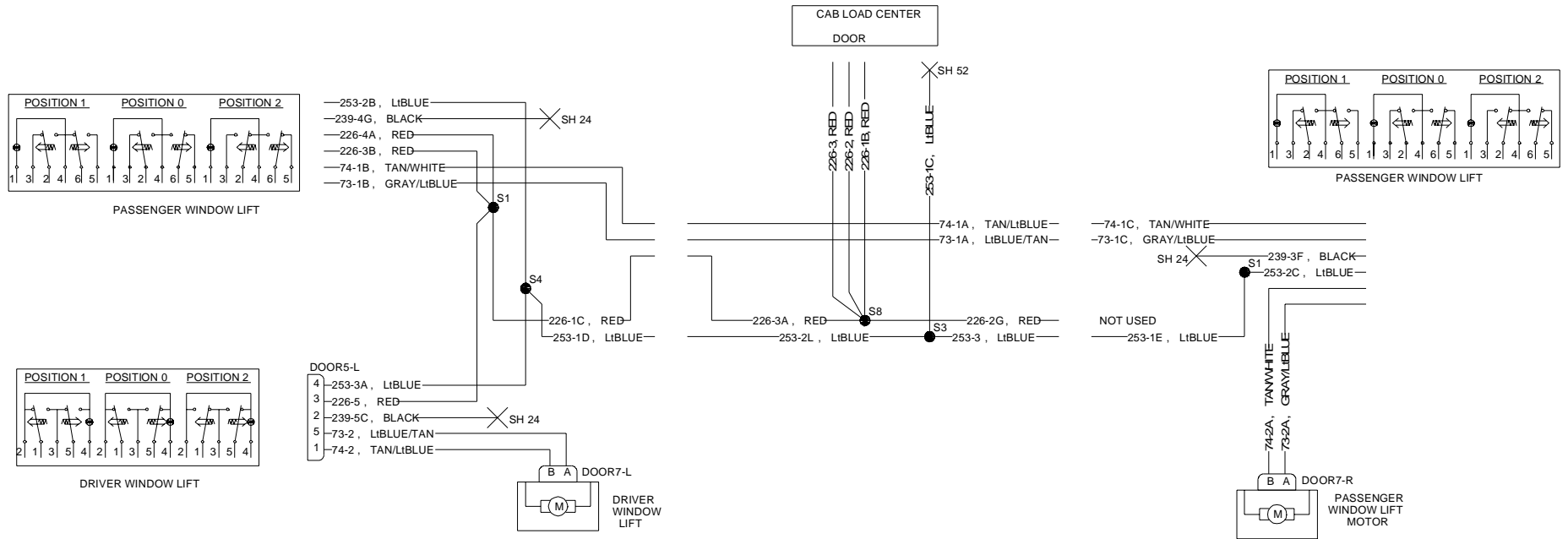

WINDOW LIFT



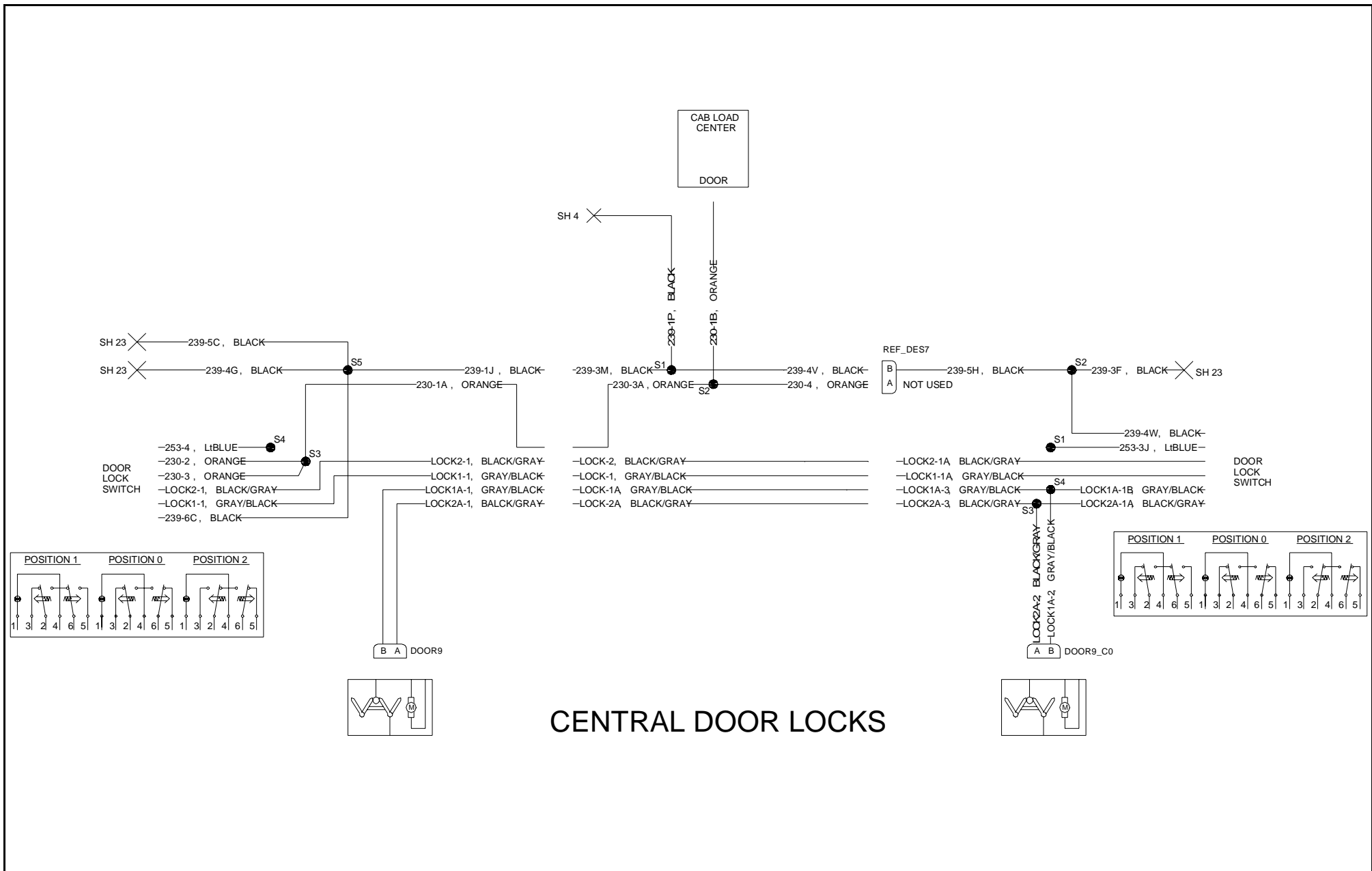

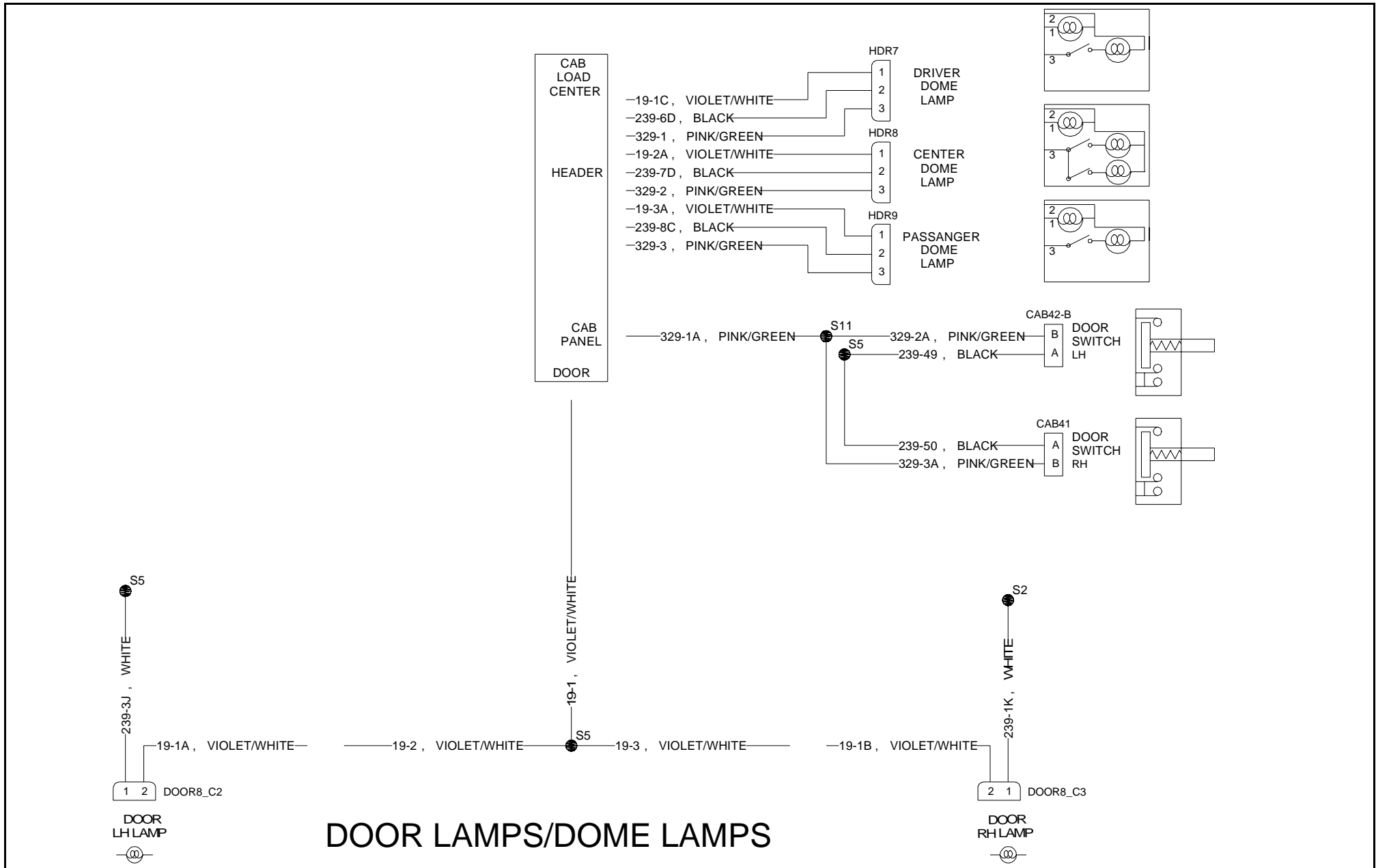

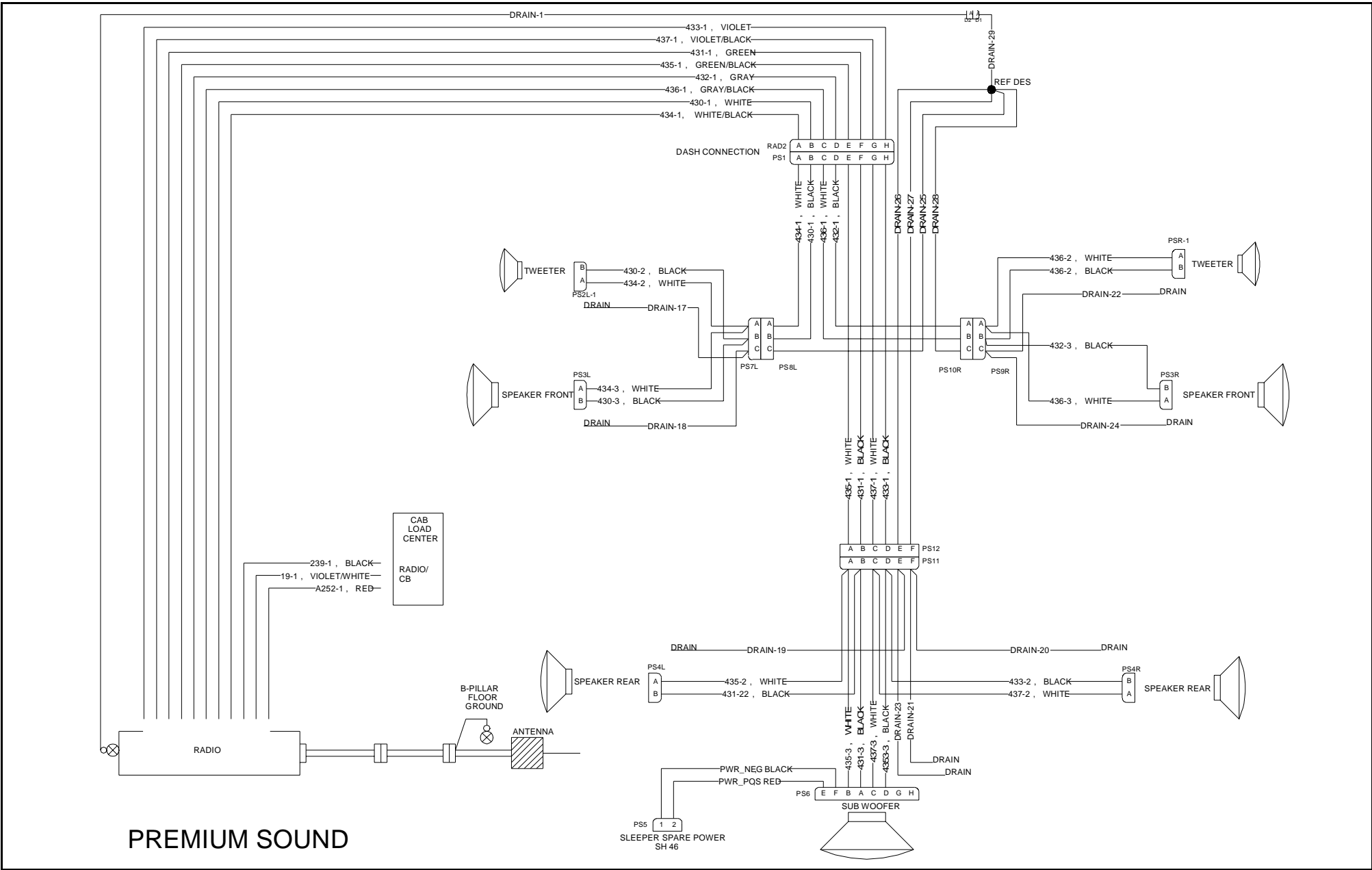

PREMIUM SOUND



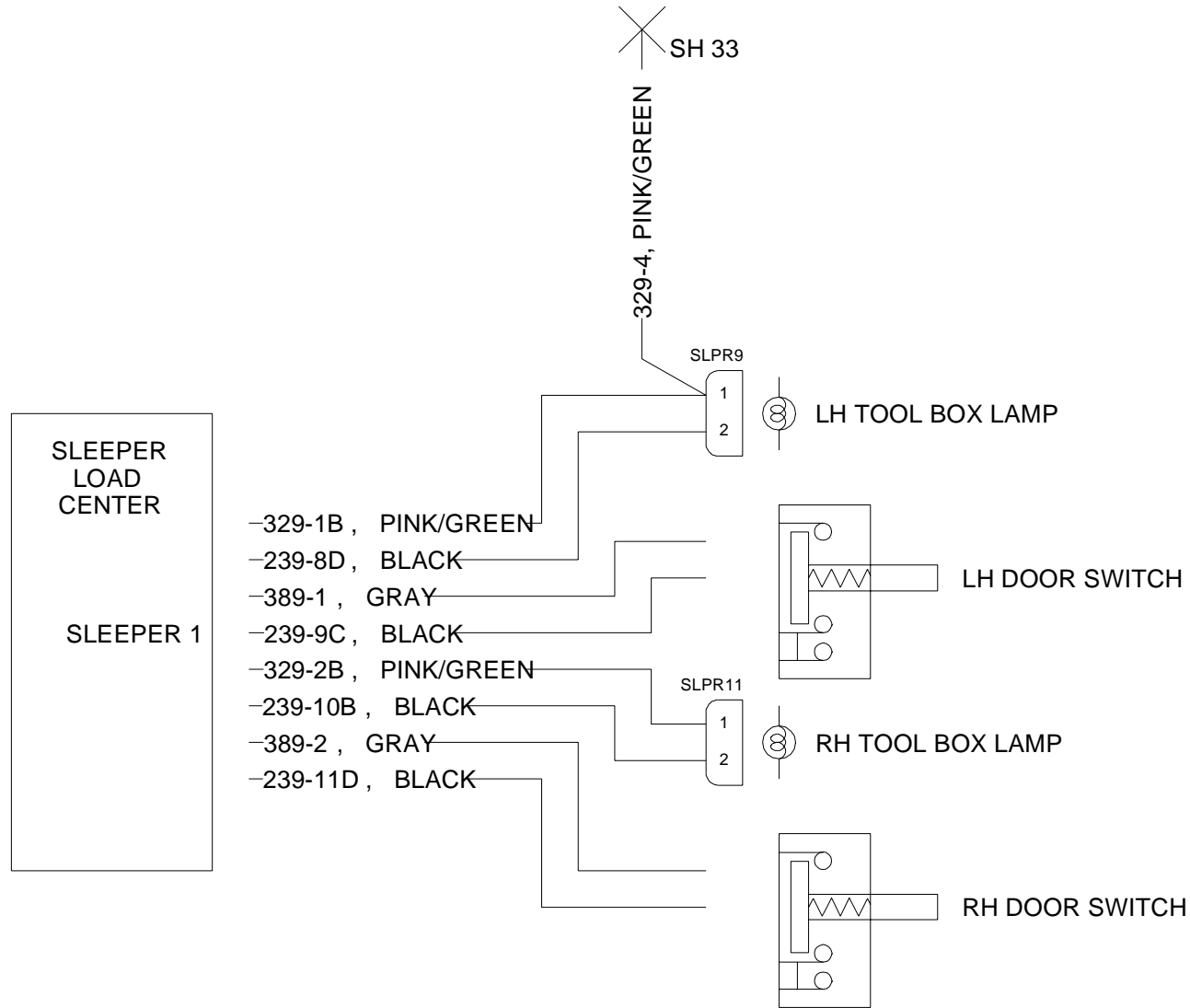

SLEEPER TOOL BOX LAMPS

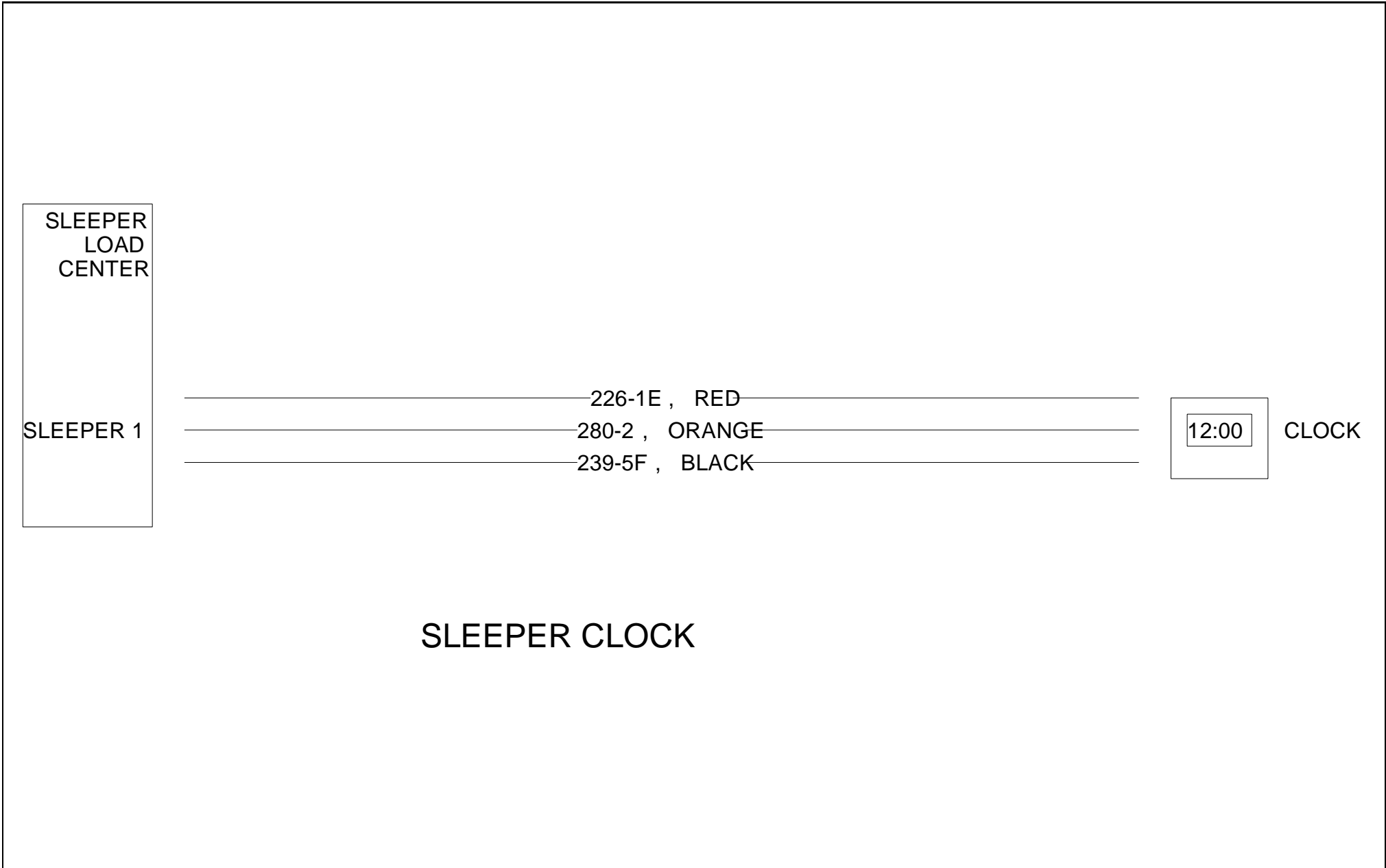

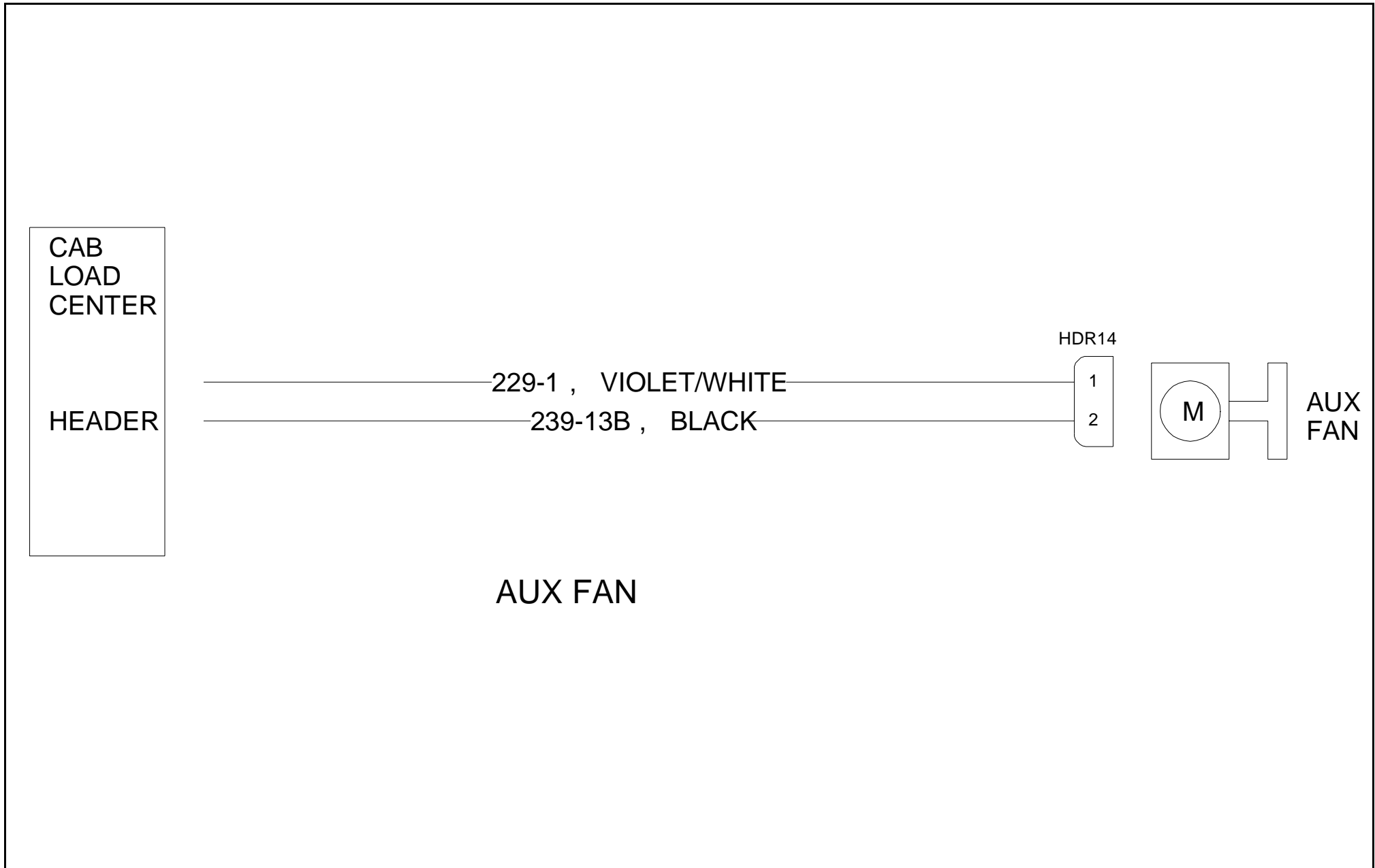

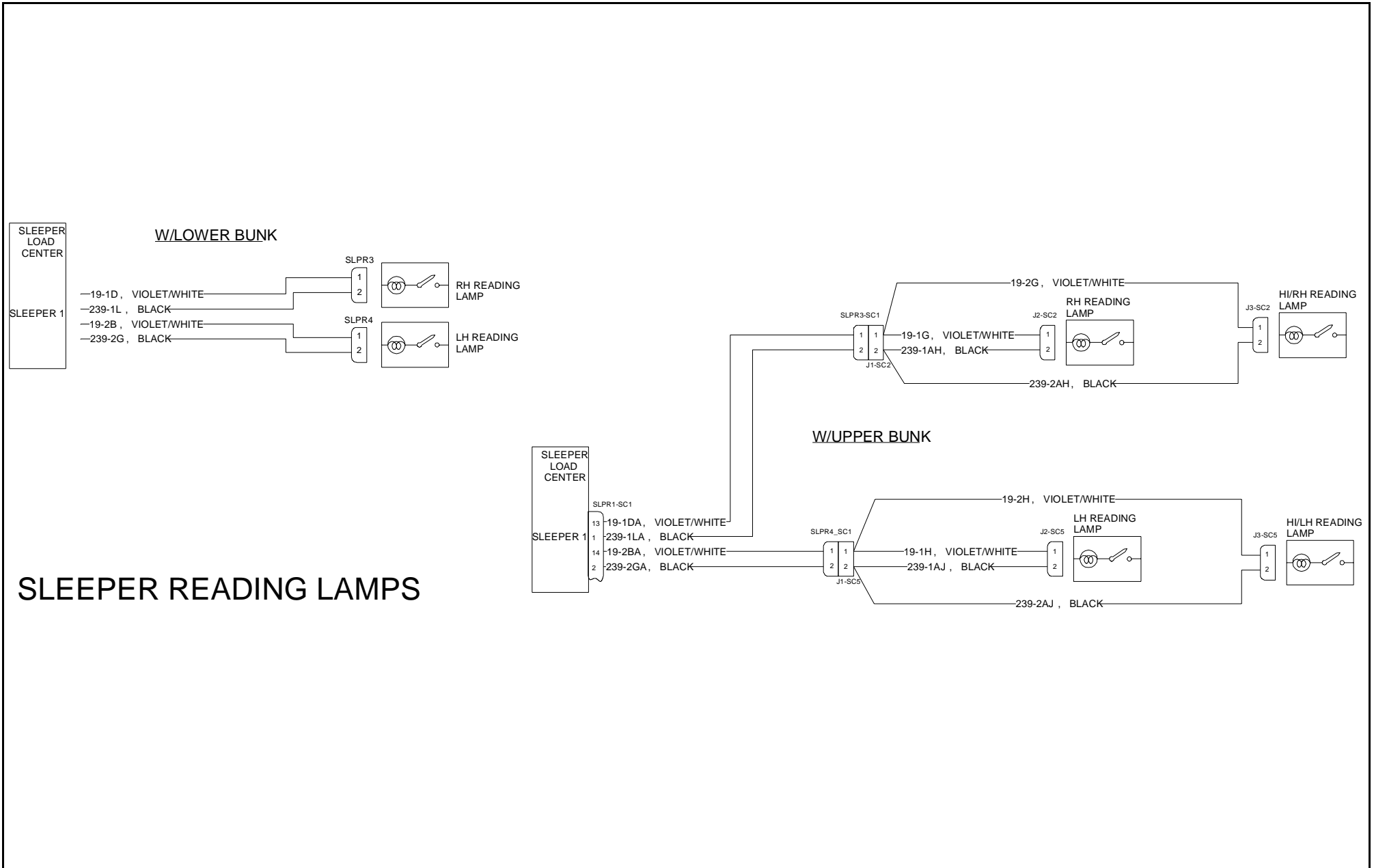

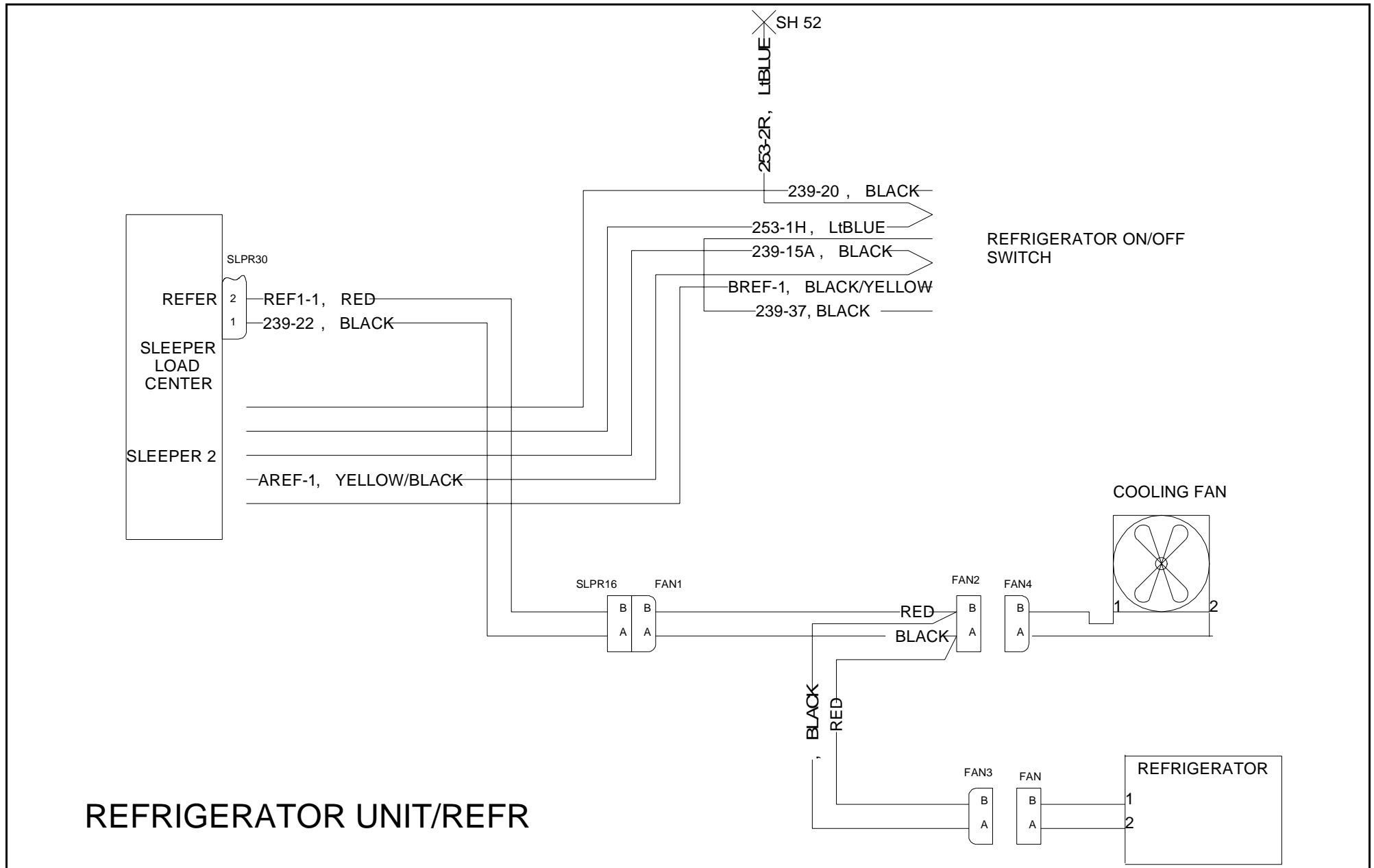

REFRIGERATOR UNIT/REFR

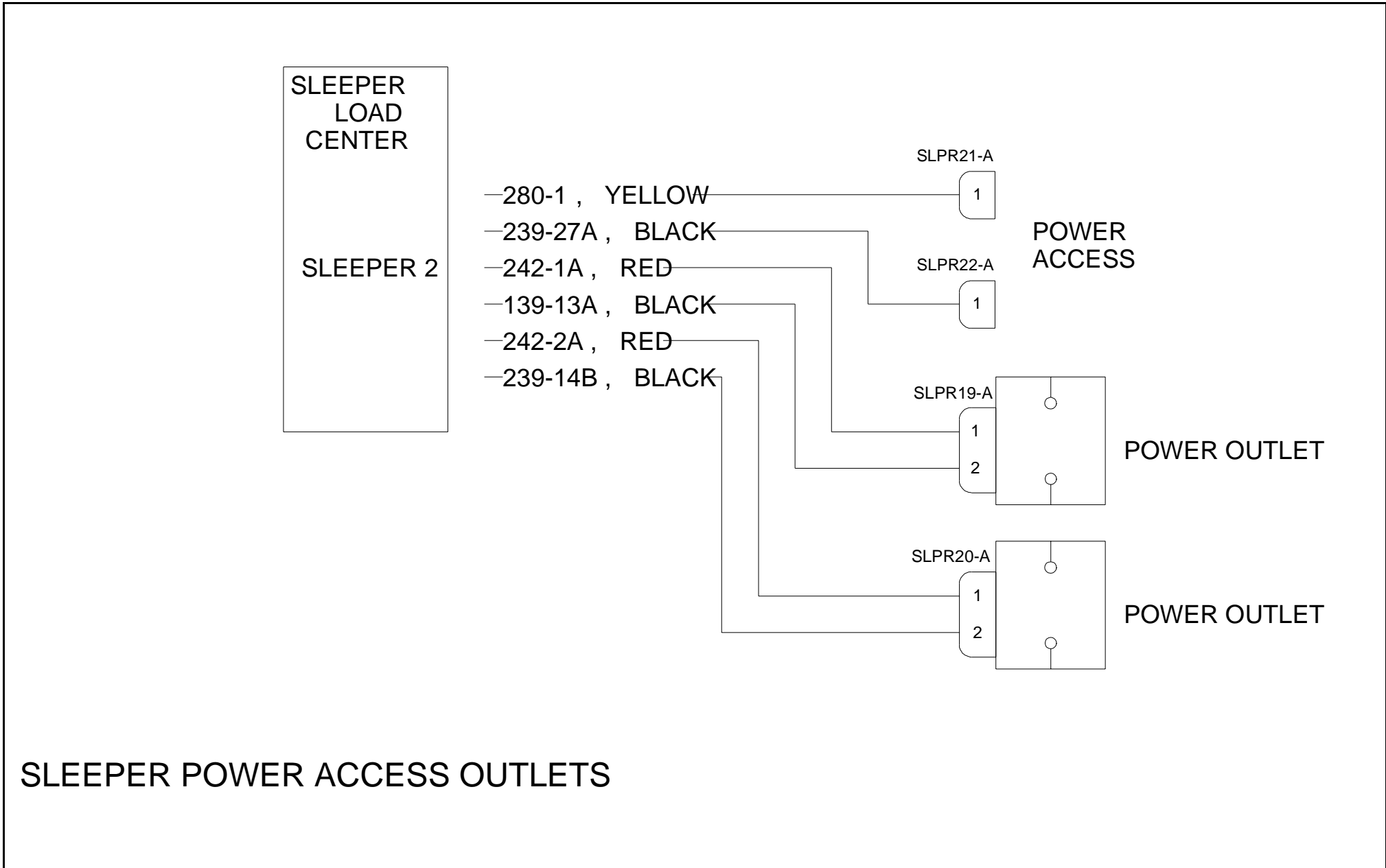

SLEEPER POWER ACCESS OUTLETS

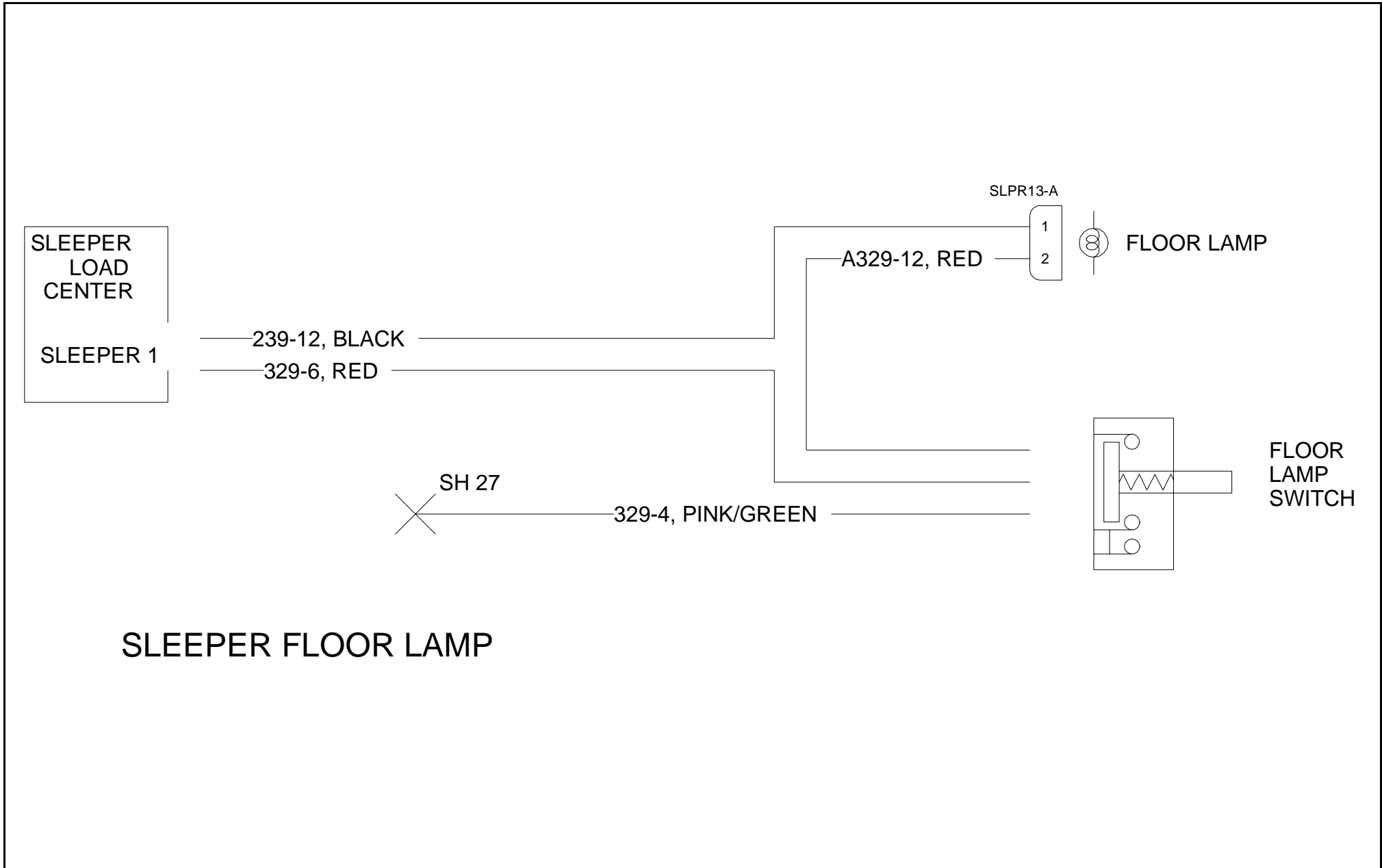

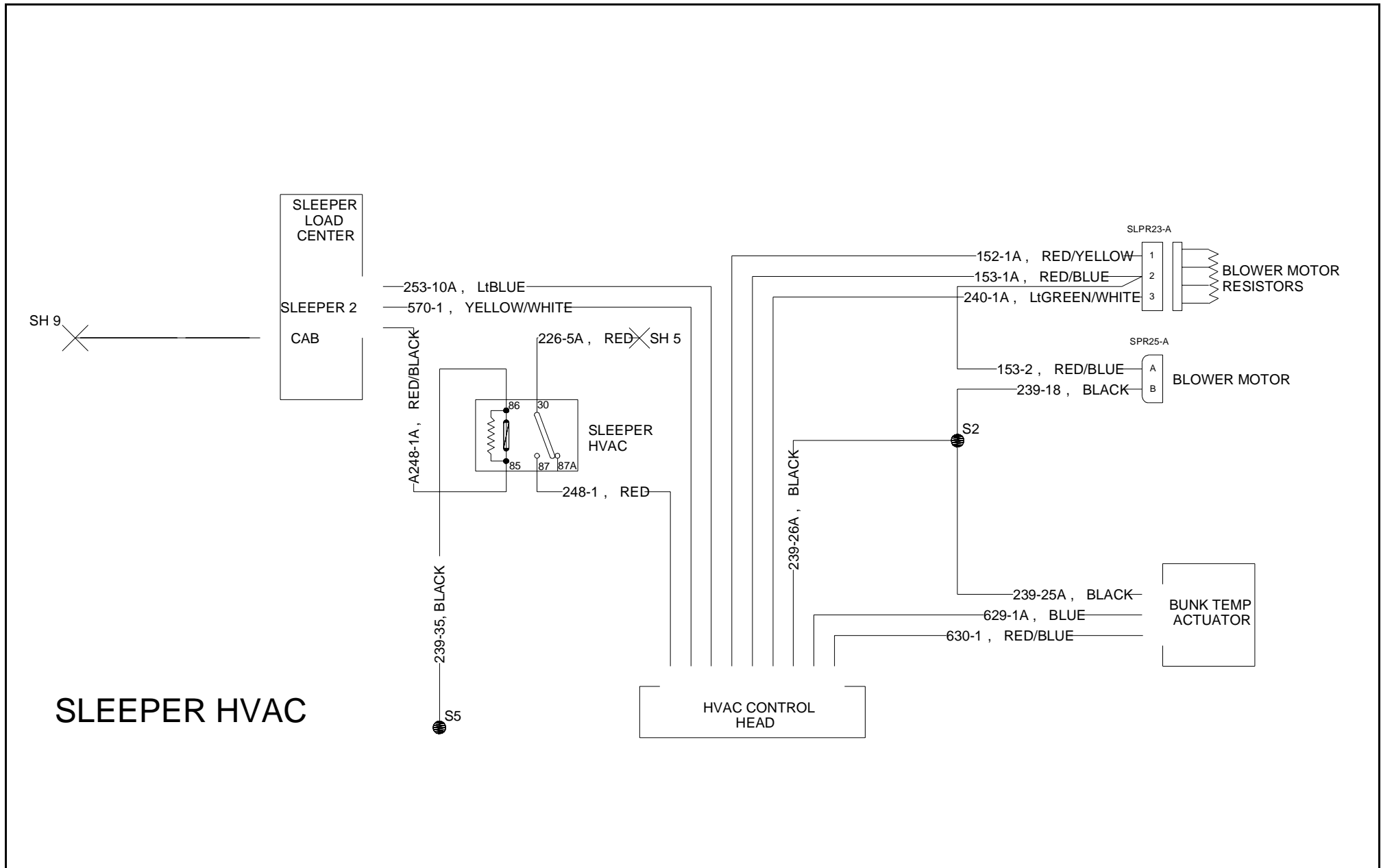

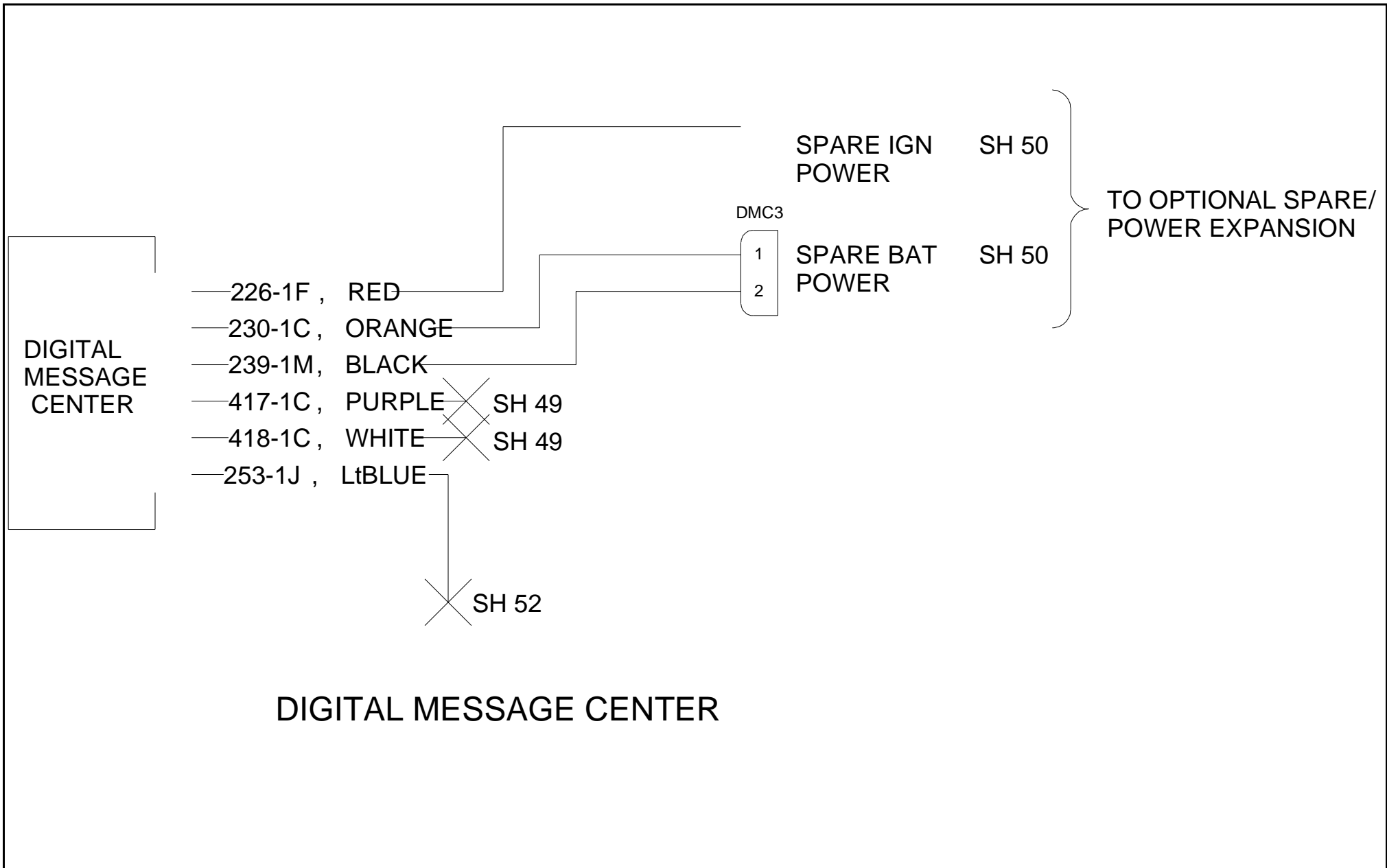

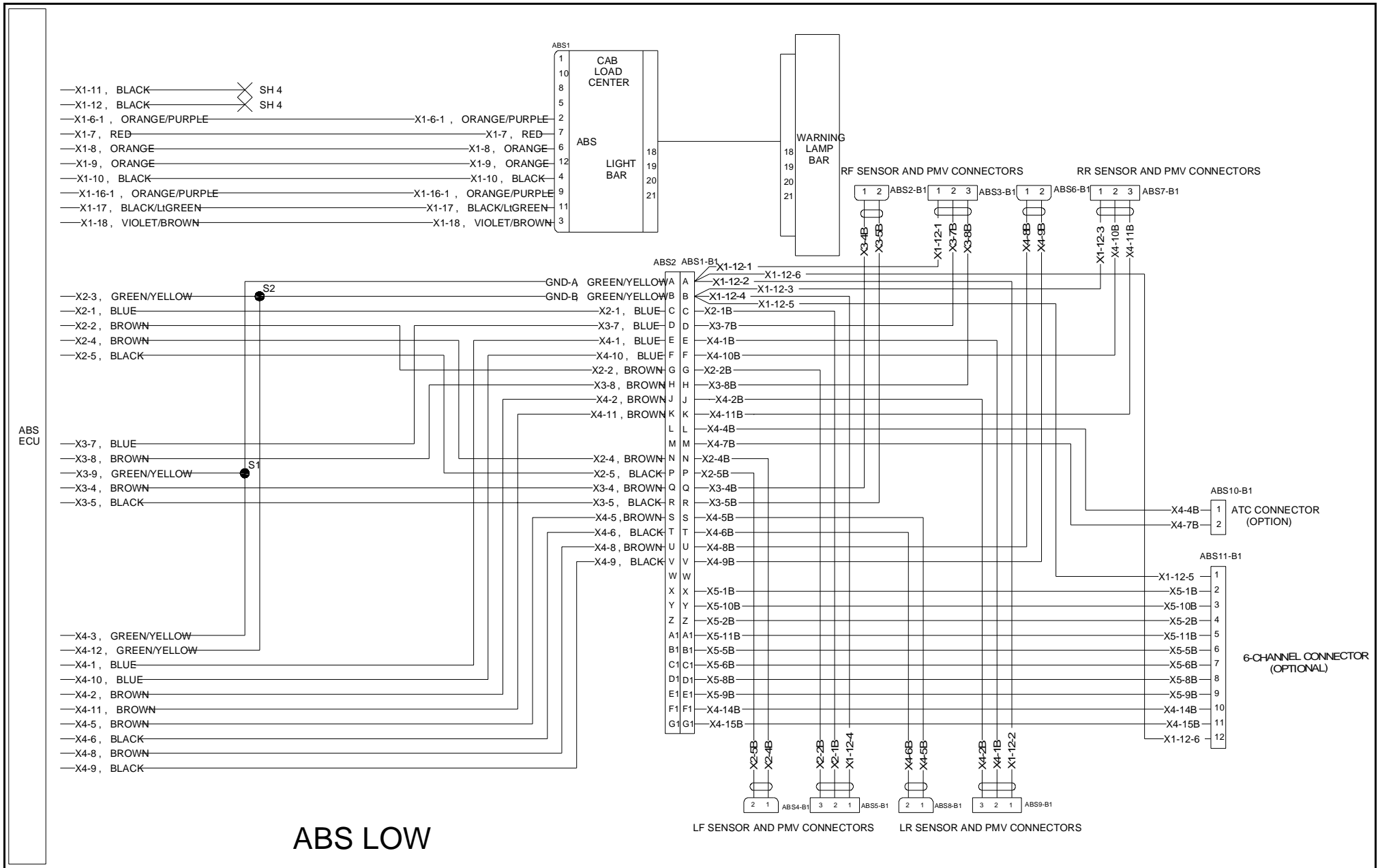

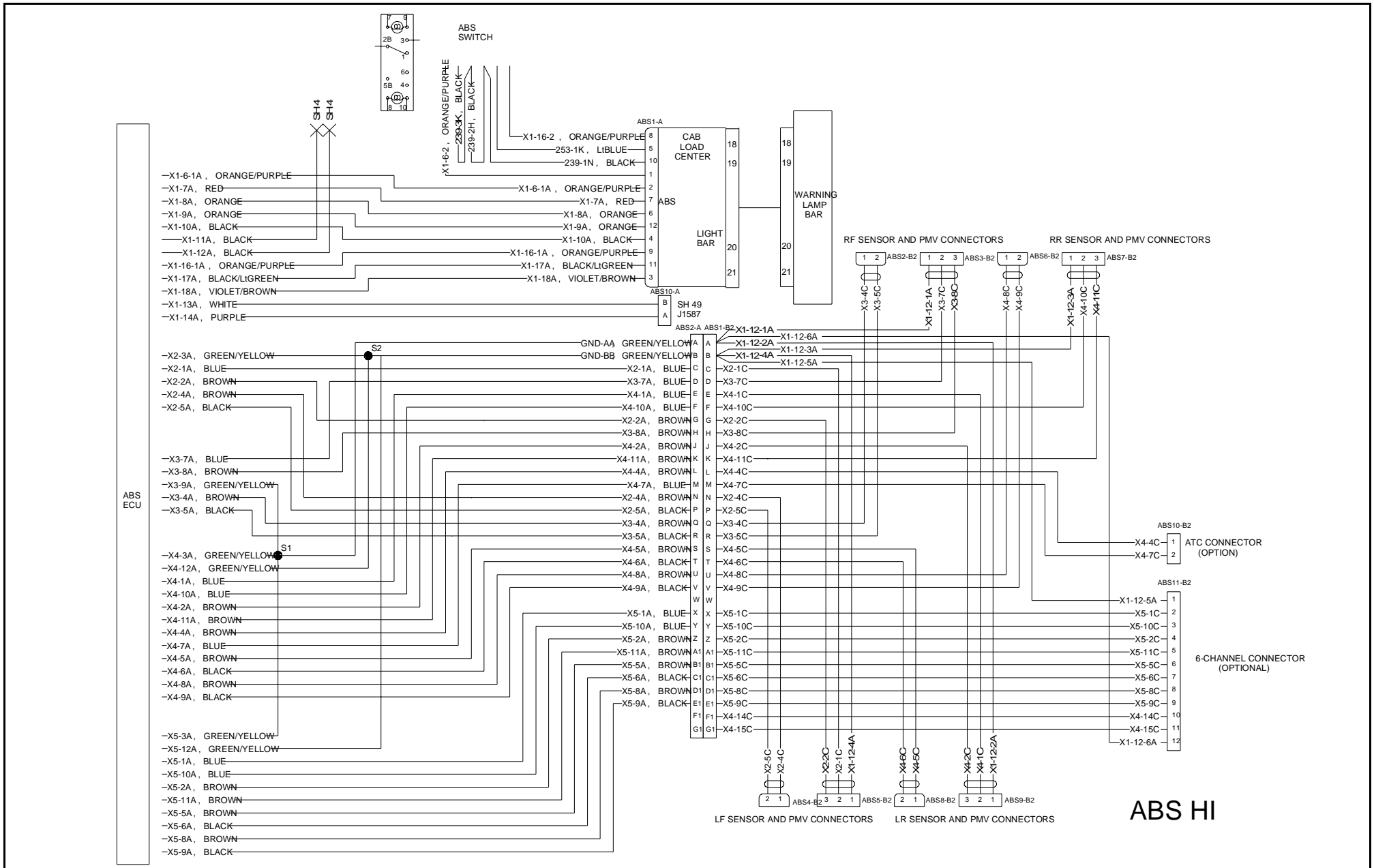

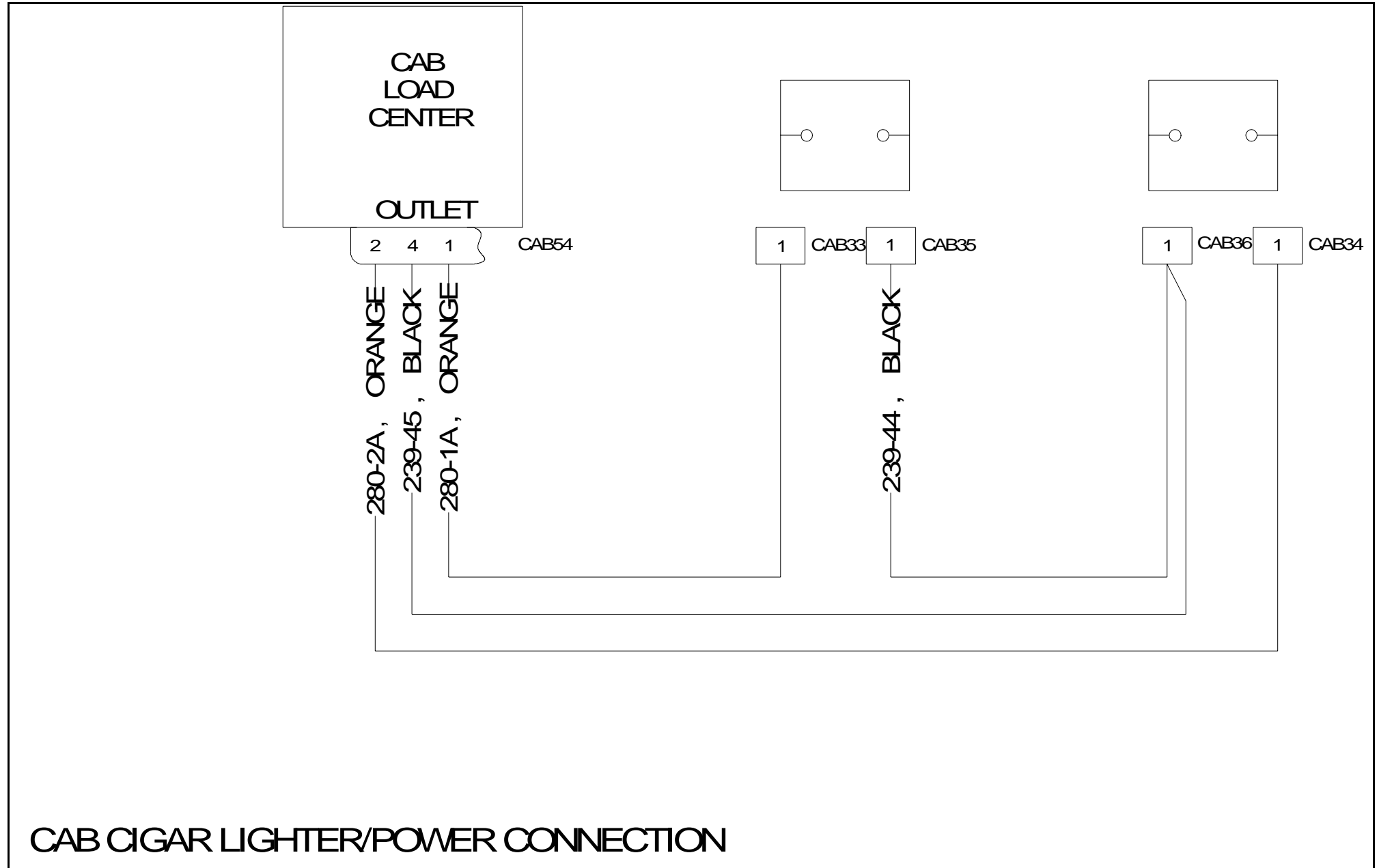

CAB CIGAR LIGHTER/POWER CONNECTION

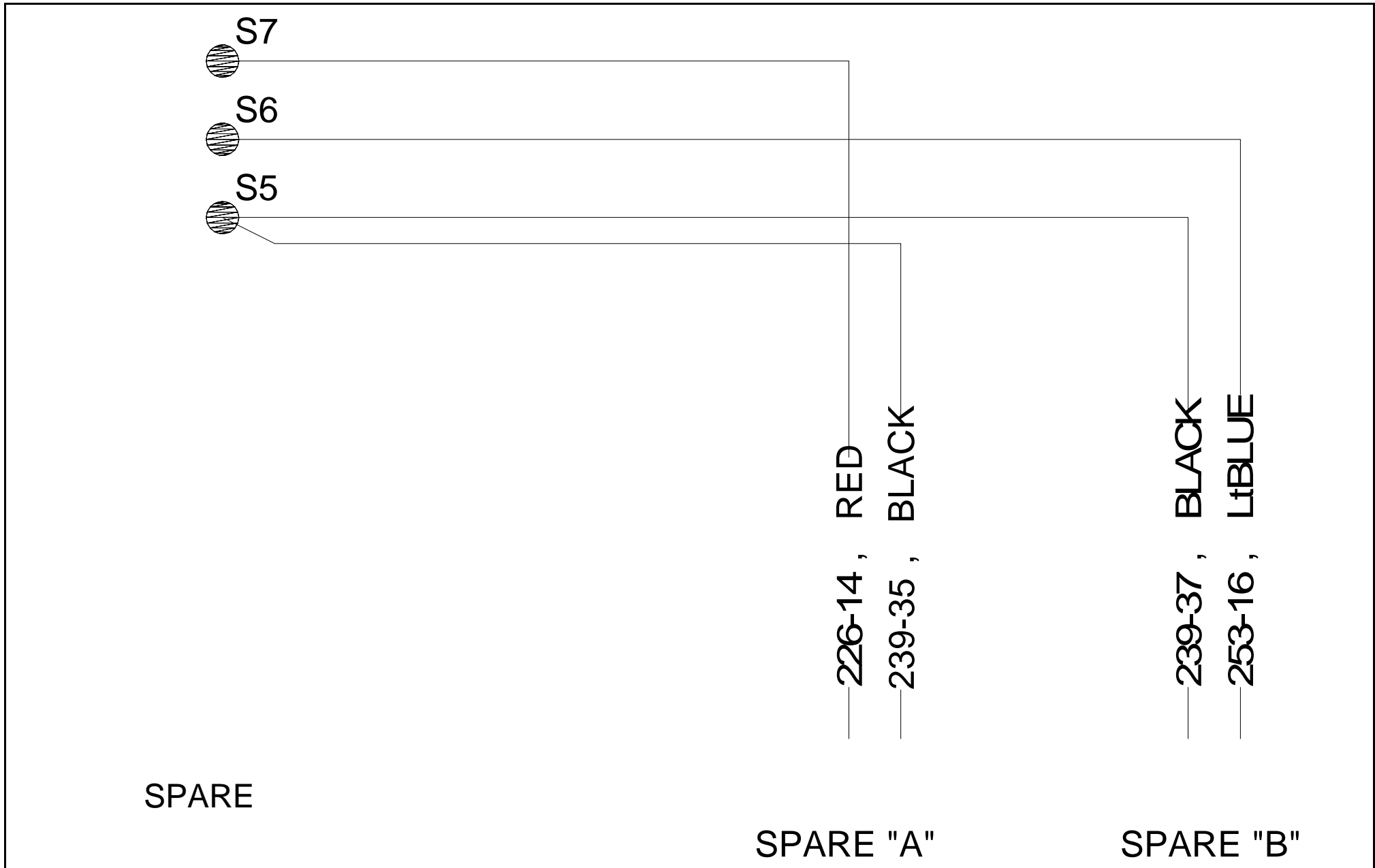

SPARE

SPARE "A"

SPARE "B"

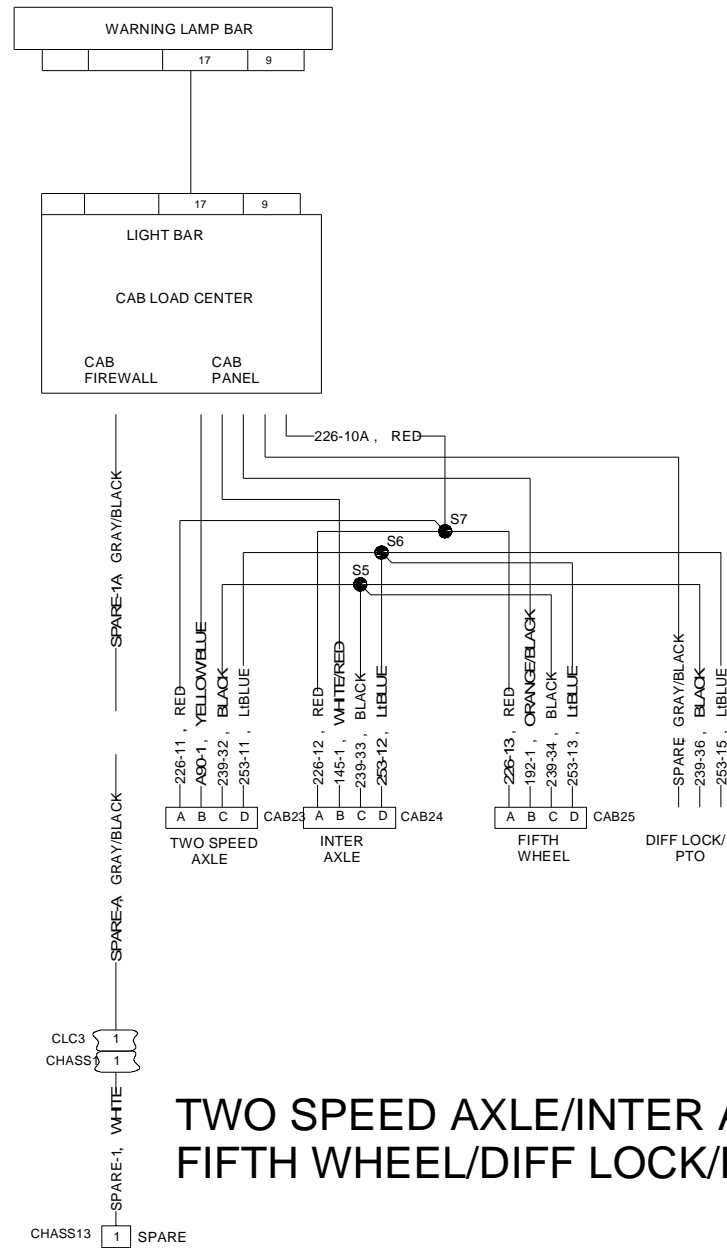

TWO SPEED AXLE/INTER AXLE/
FIFTH WHEEL/DIFF LOCK/PTO

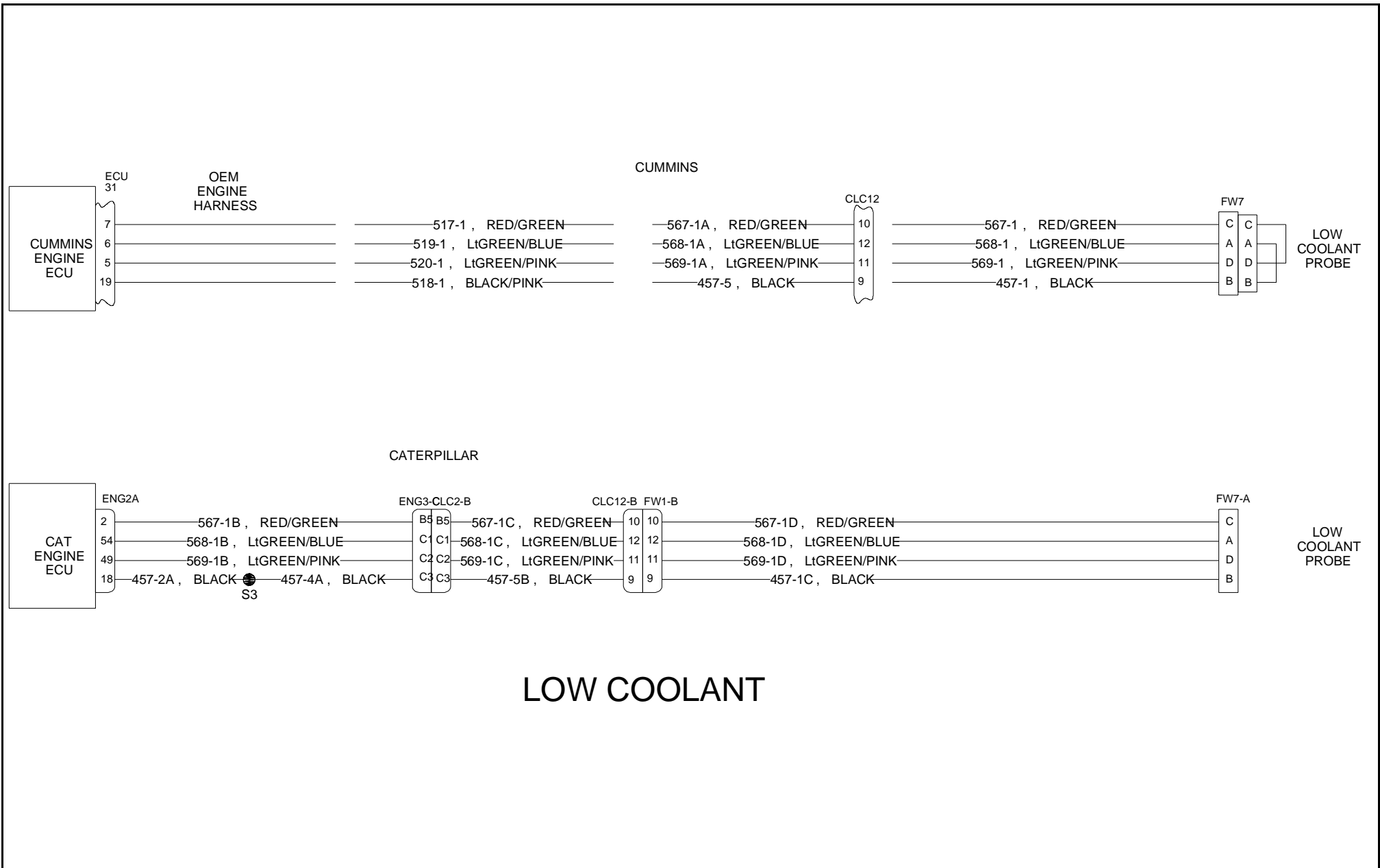

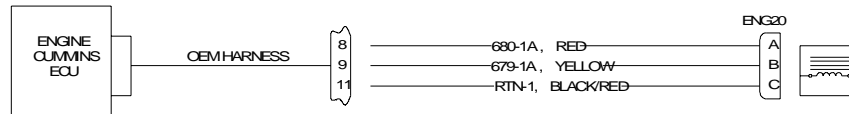
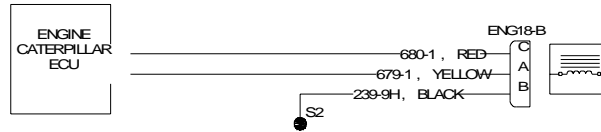

EATON TOP 2 TRANSMISSION

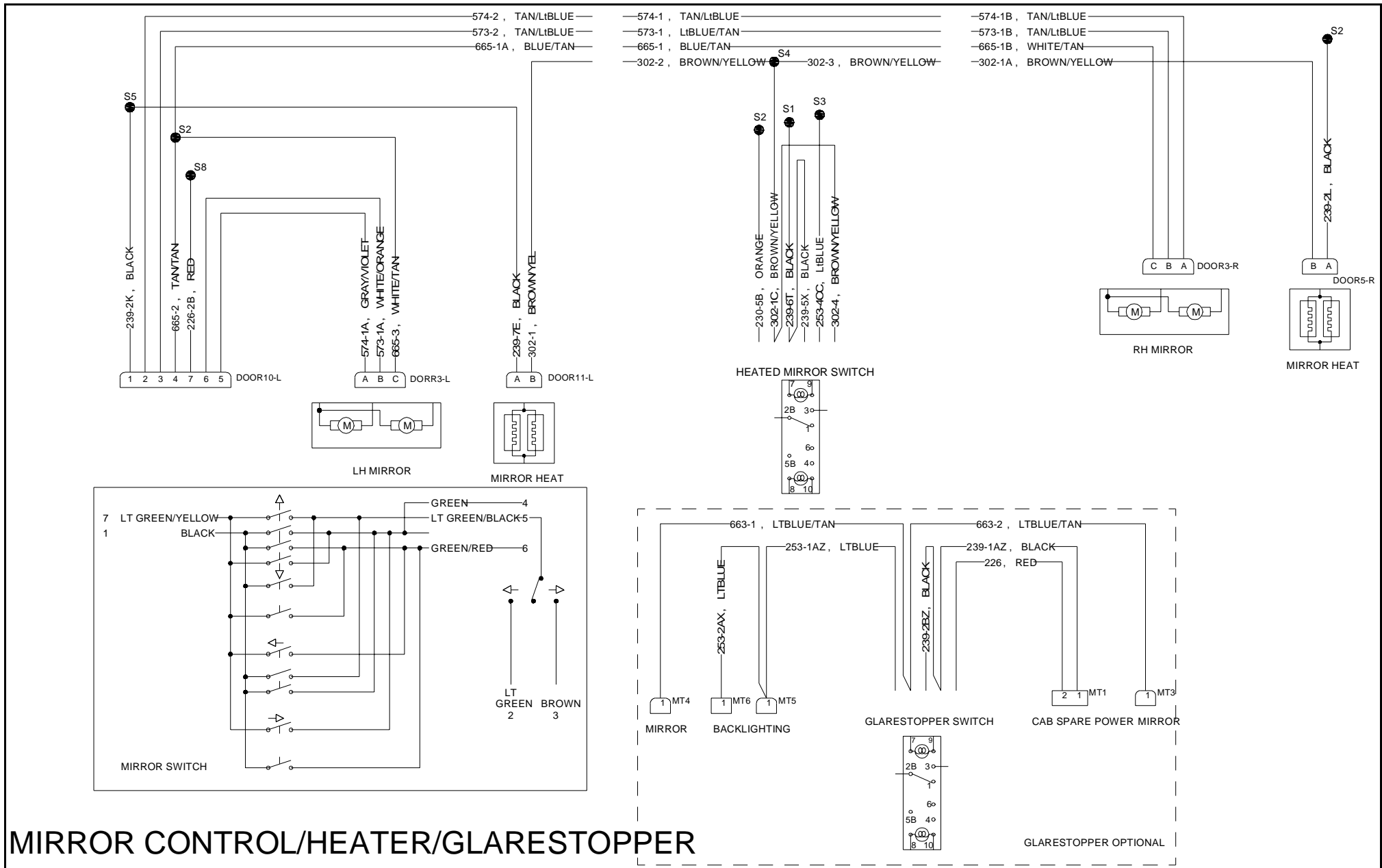

MIRROR CONTROL/HEATER/GLARESTOPPER

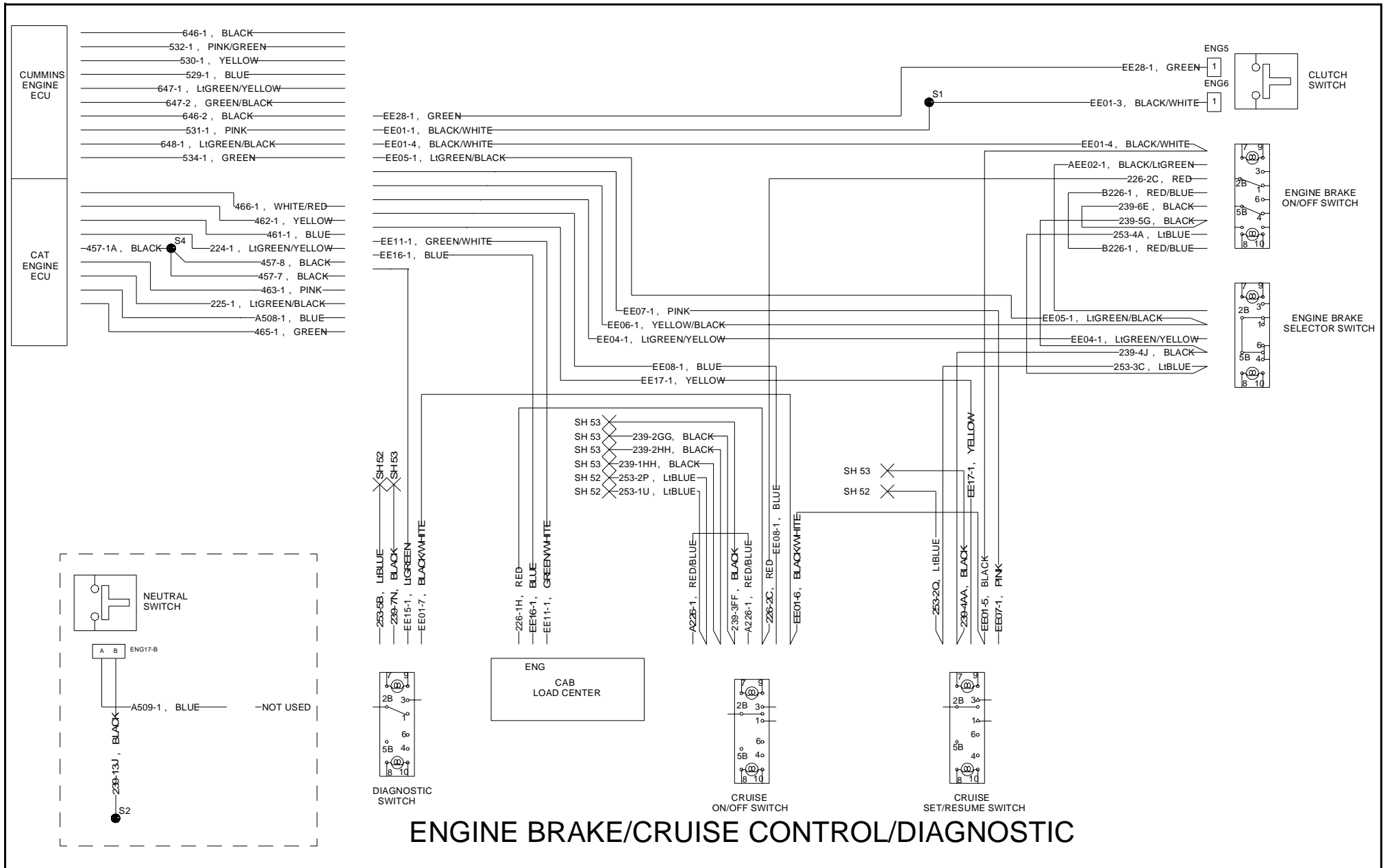

ENGINE BRAKE/CRUISE CONTROL/DIAGNOSTIC

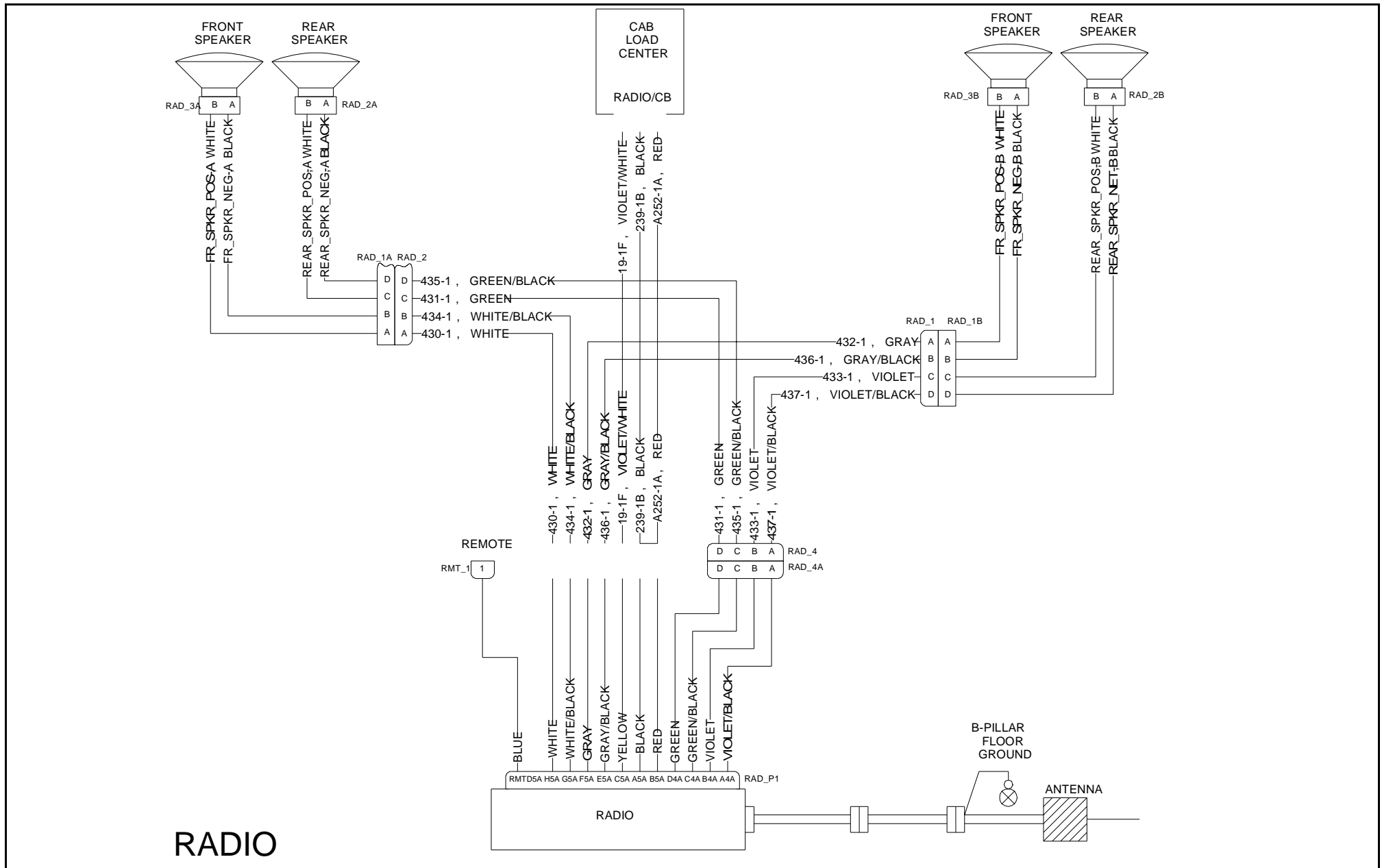

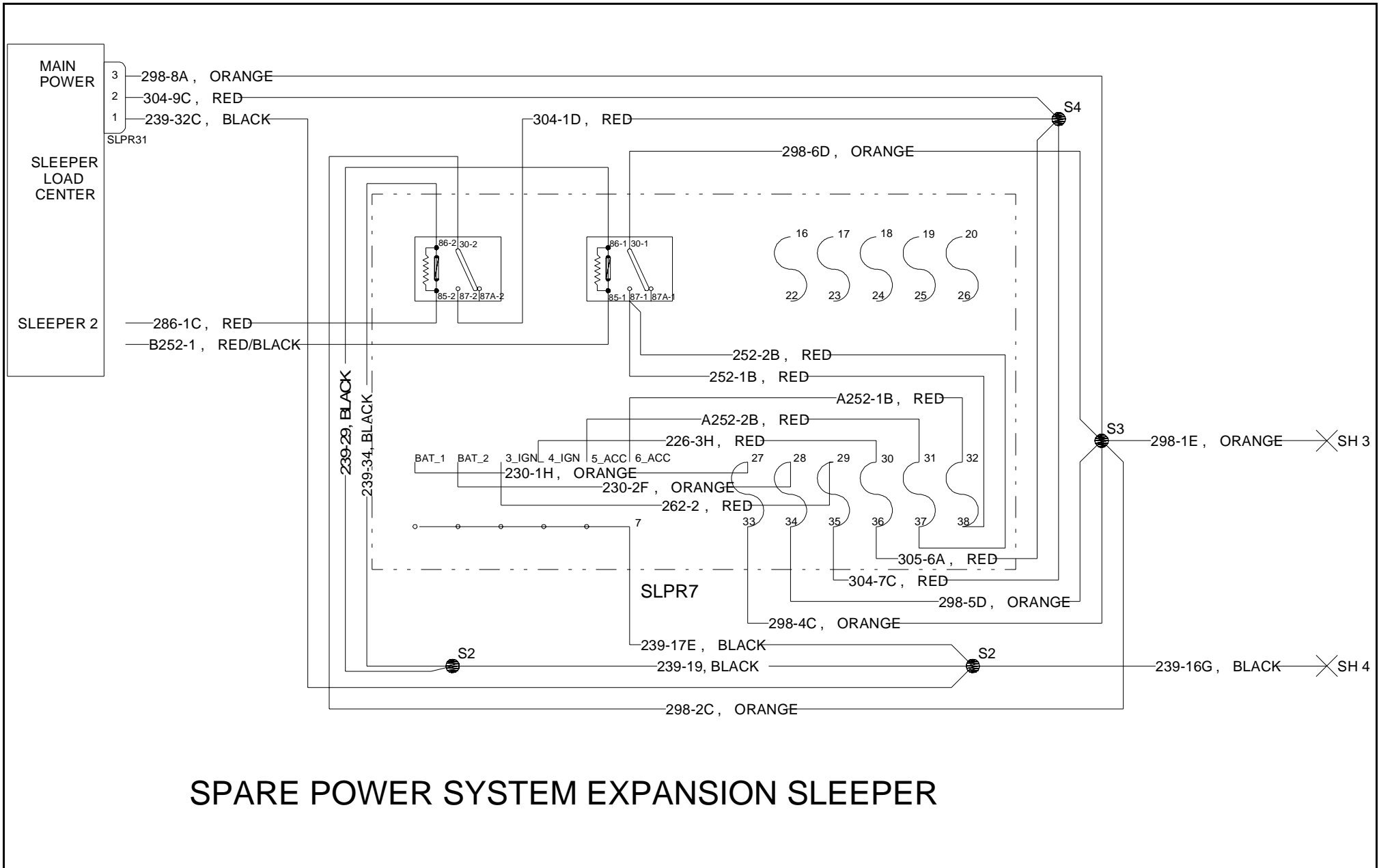

SPARE POWER SYSTEM EXPANSION SLEEPER

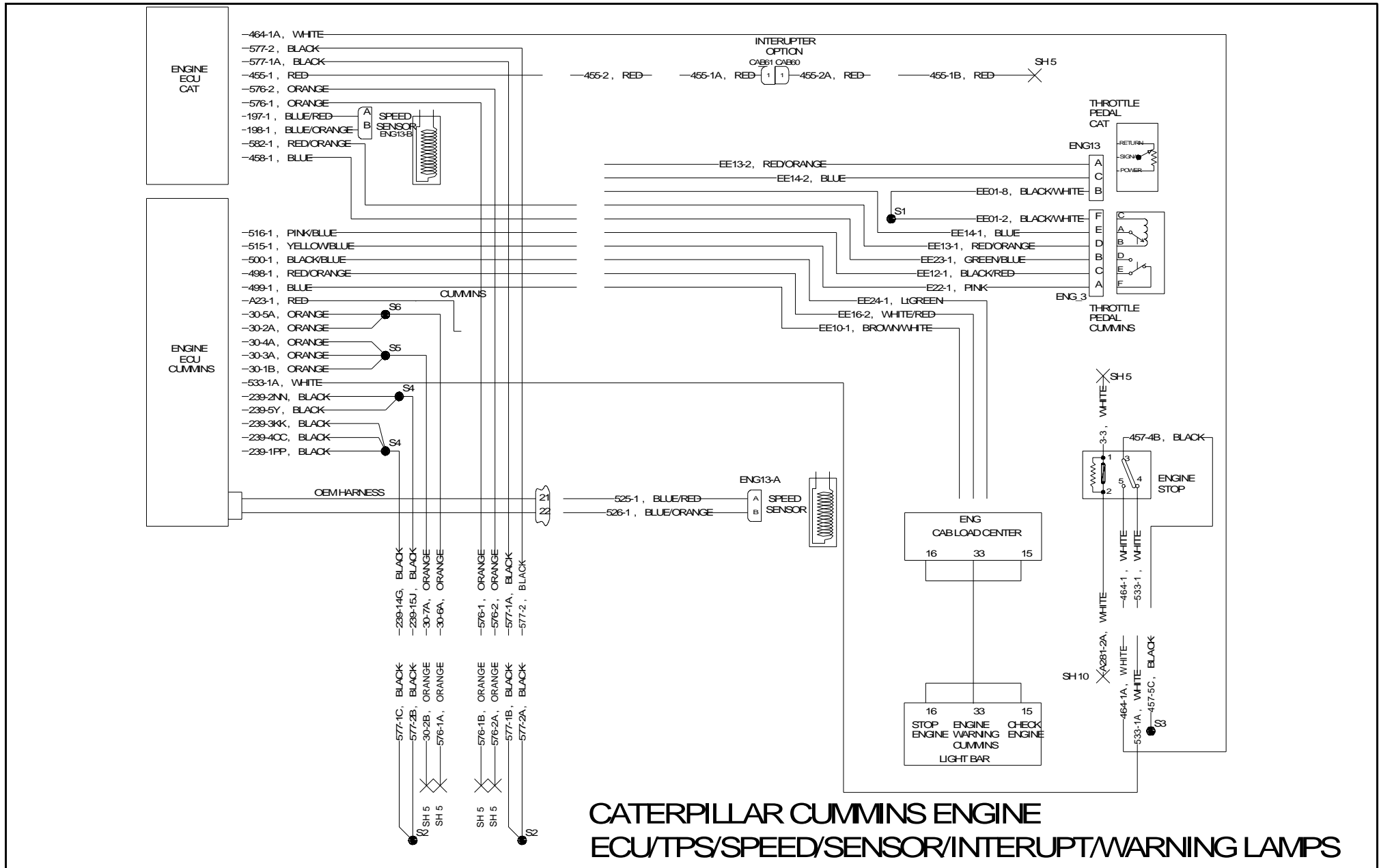

**CATERPILLAR CUMMINS ENGINE
ECU/TPS/SPEED/SENSOR/INTERUPT/WARNING LAMPS**

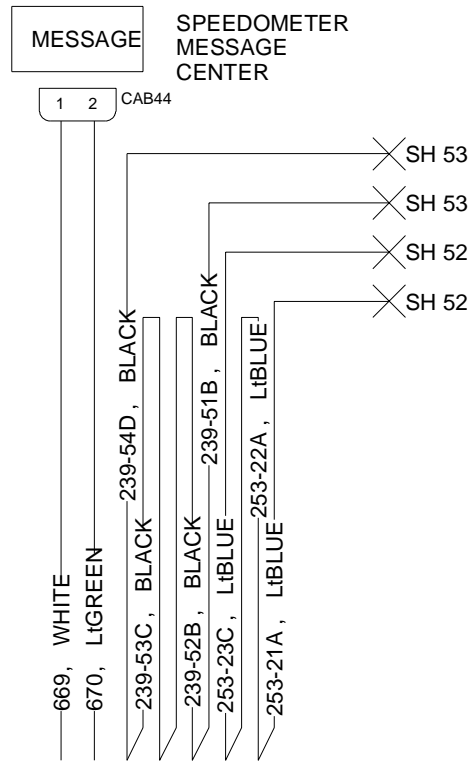

SMC SELECT/RESET

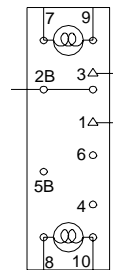

SPEEDO MESSAGE CENTER (SMC)

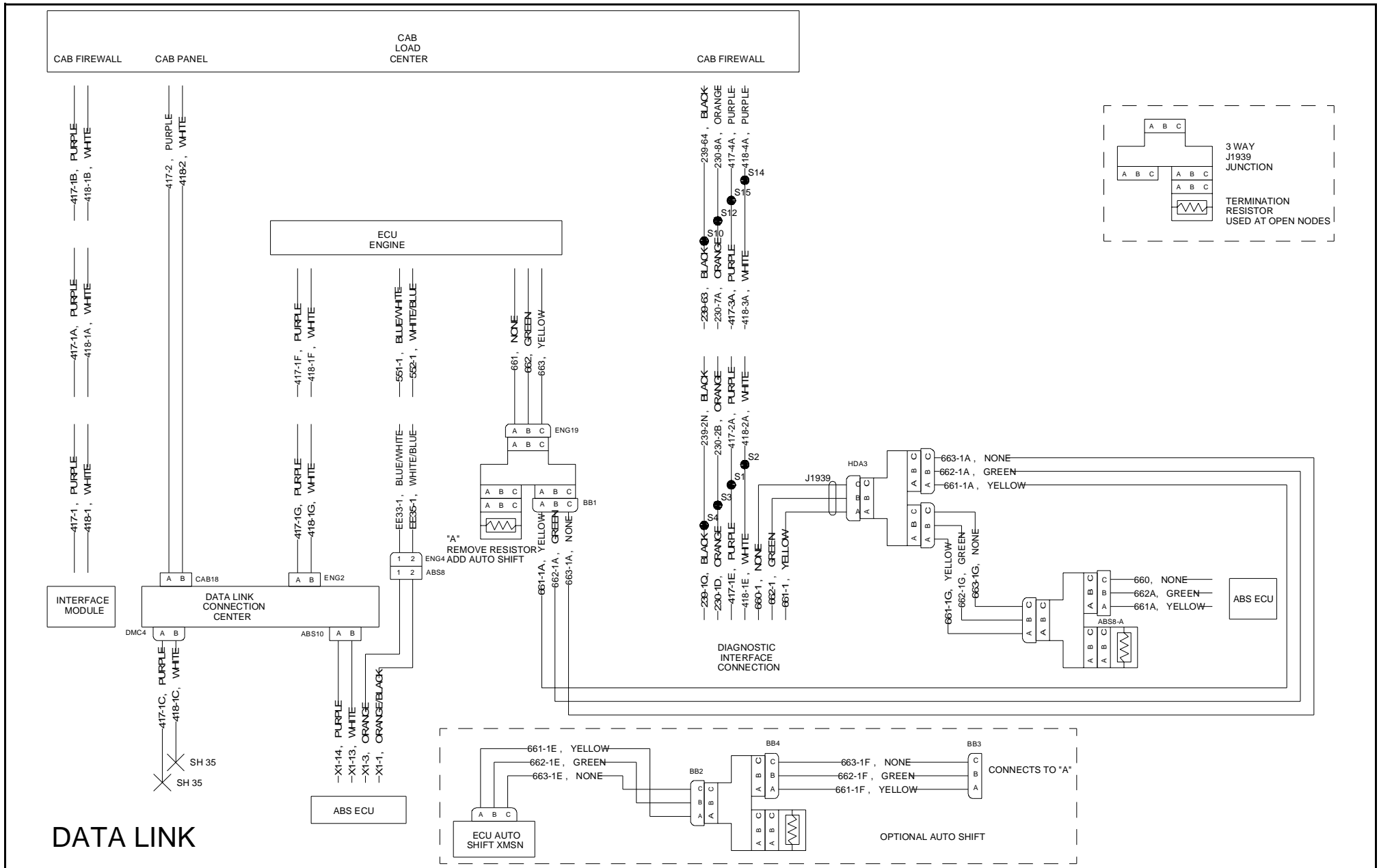

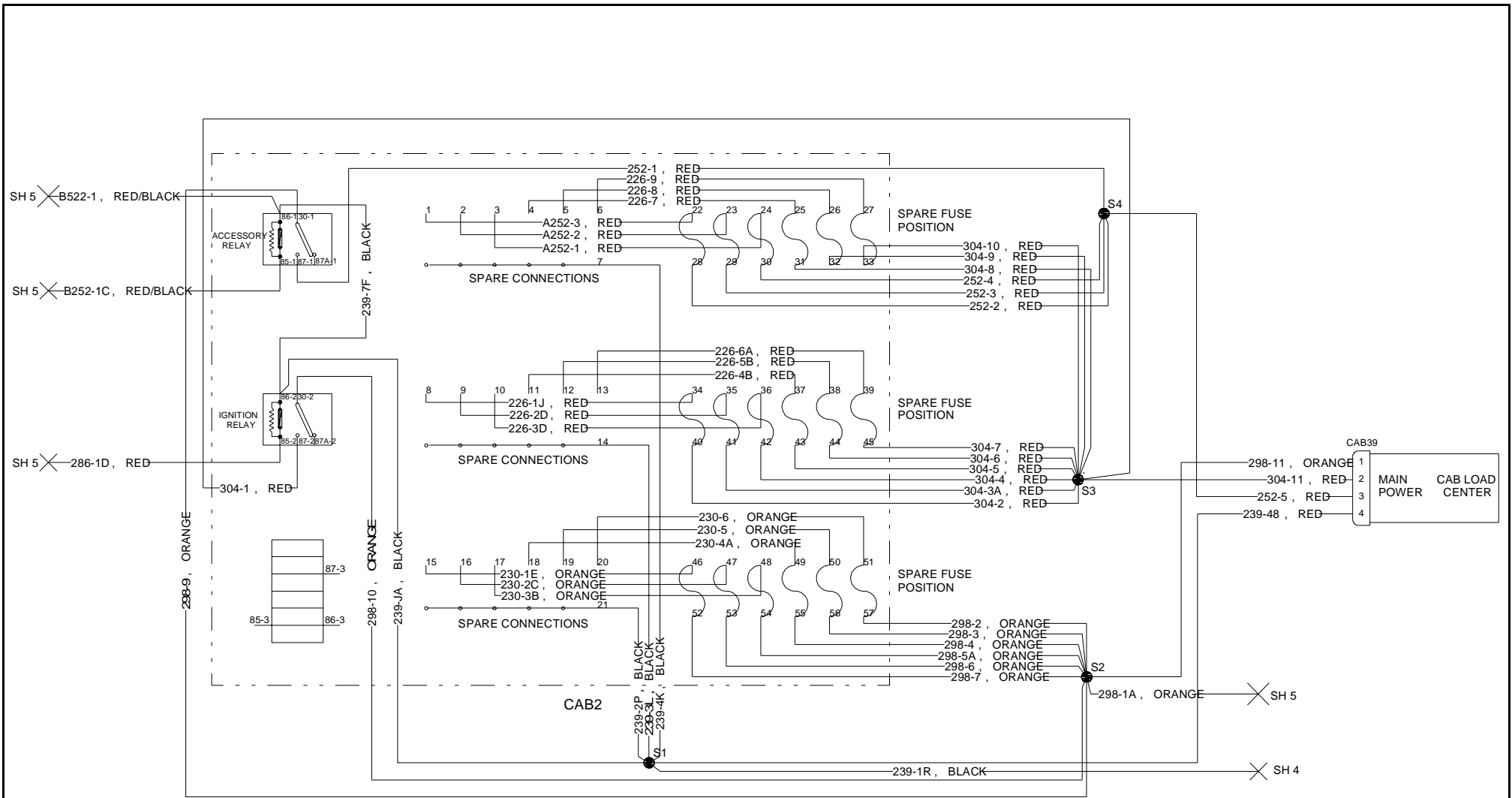

CAB SPARE POWER SYSTEM EXPANSION

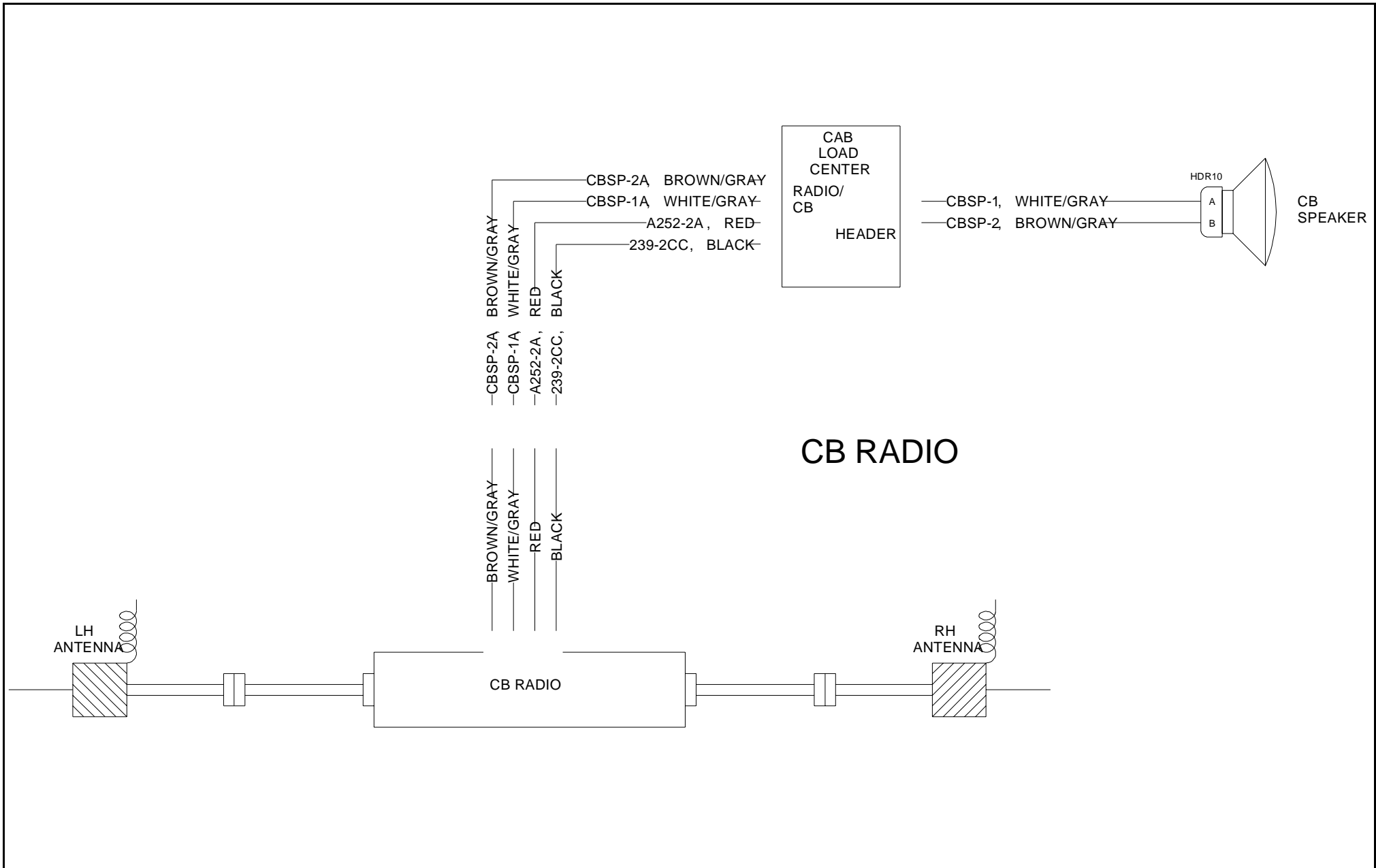

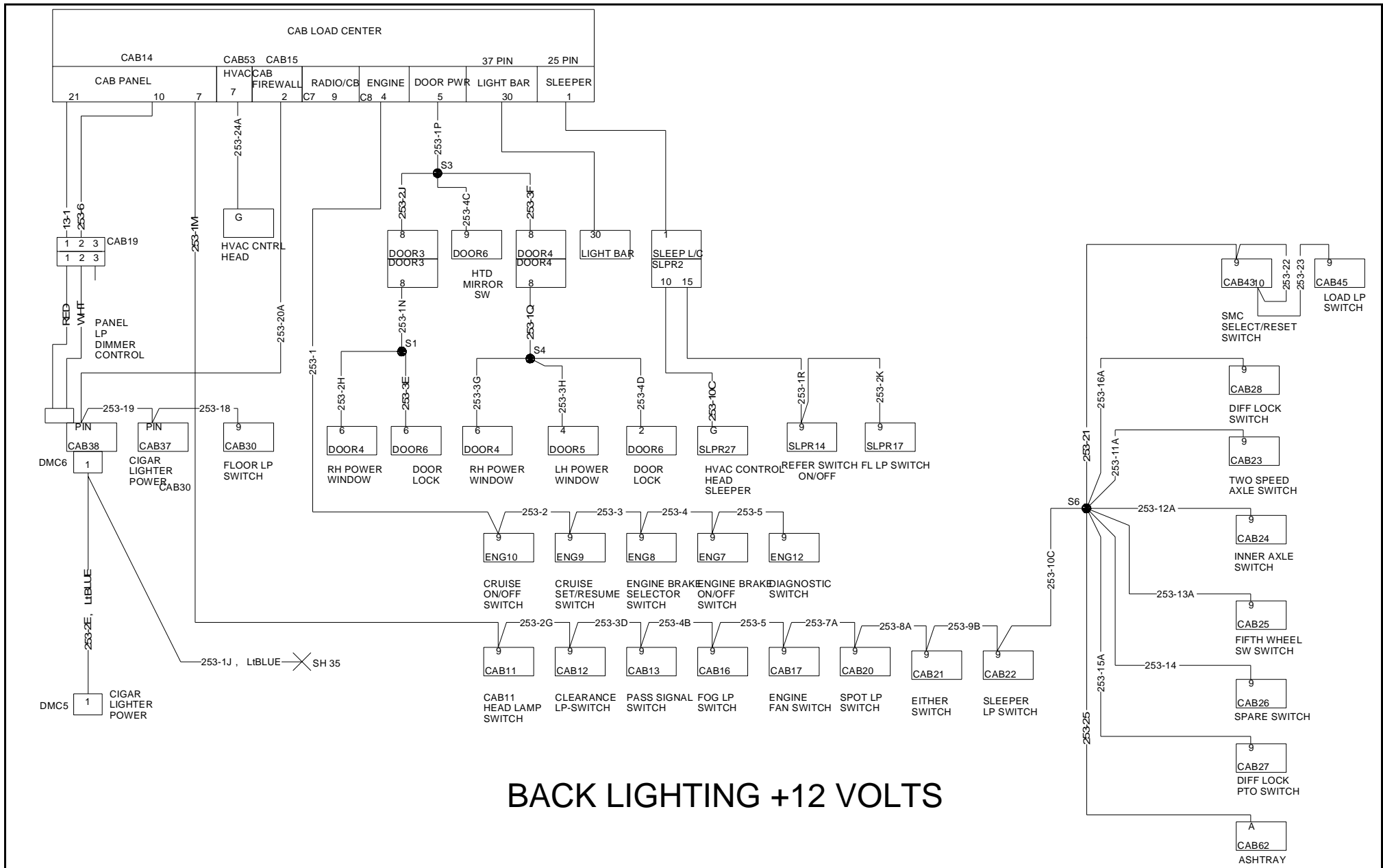

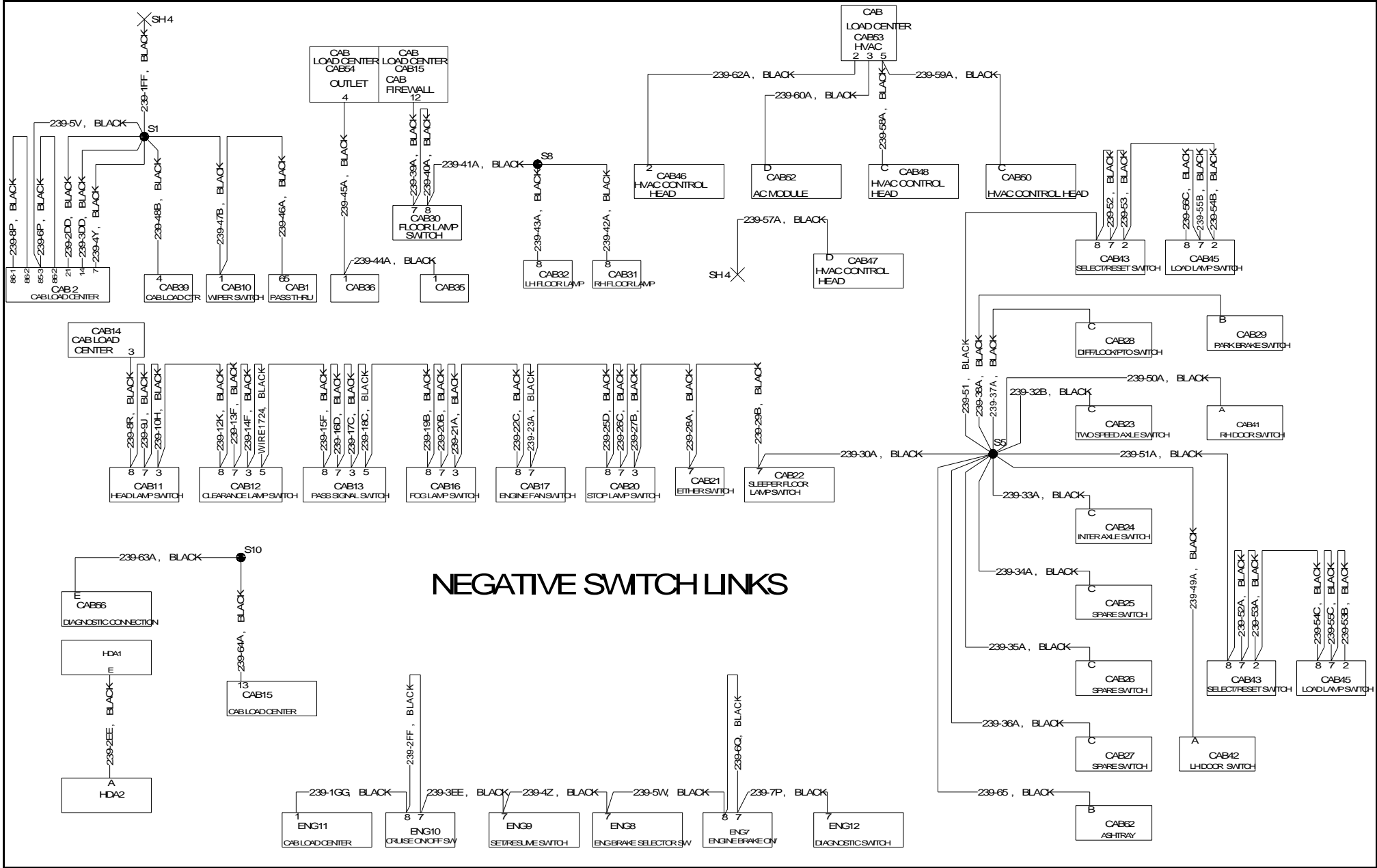

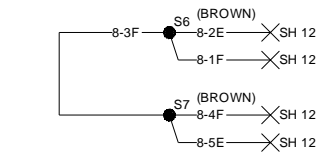
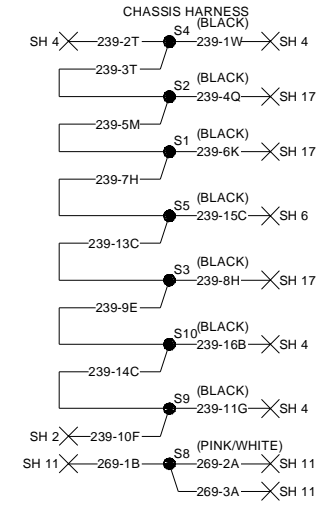
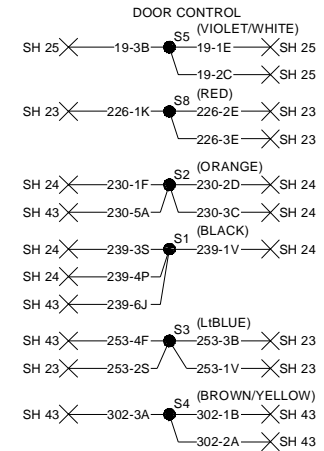
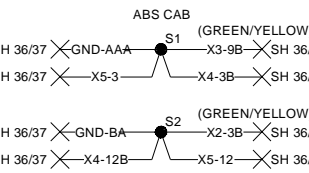
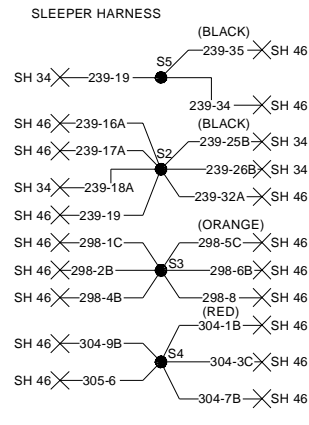
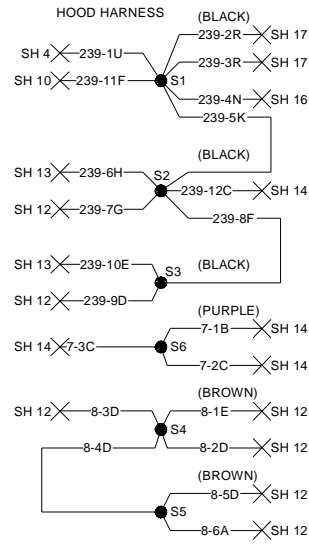
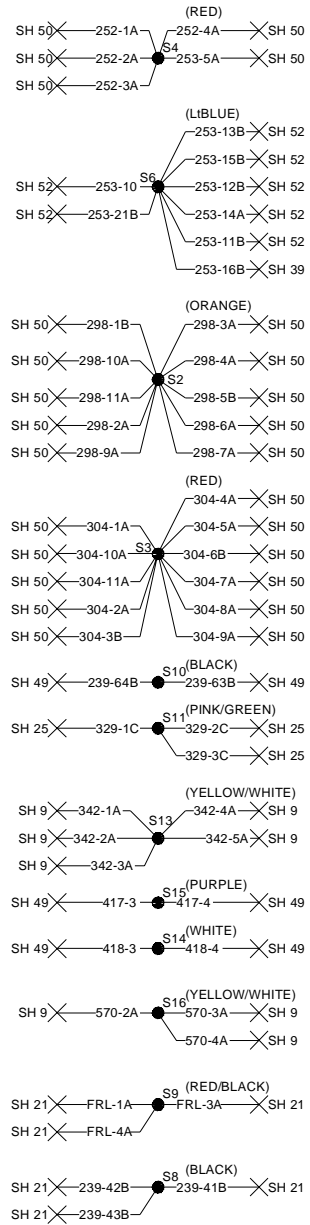
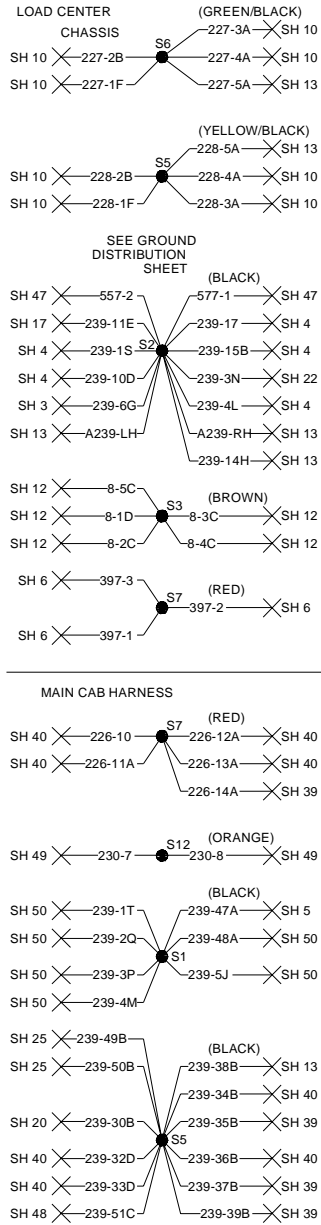

SPLICE LOCATION DISTRIBUTION

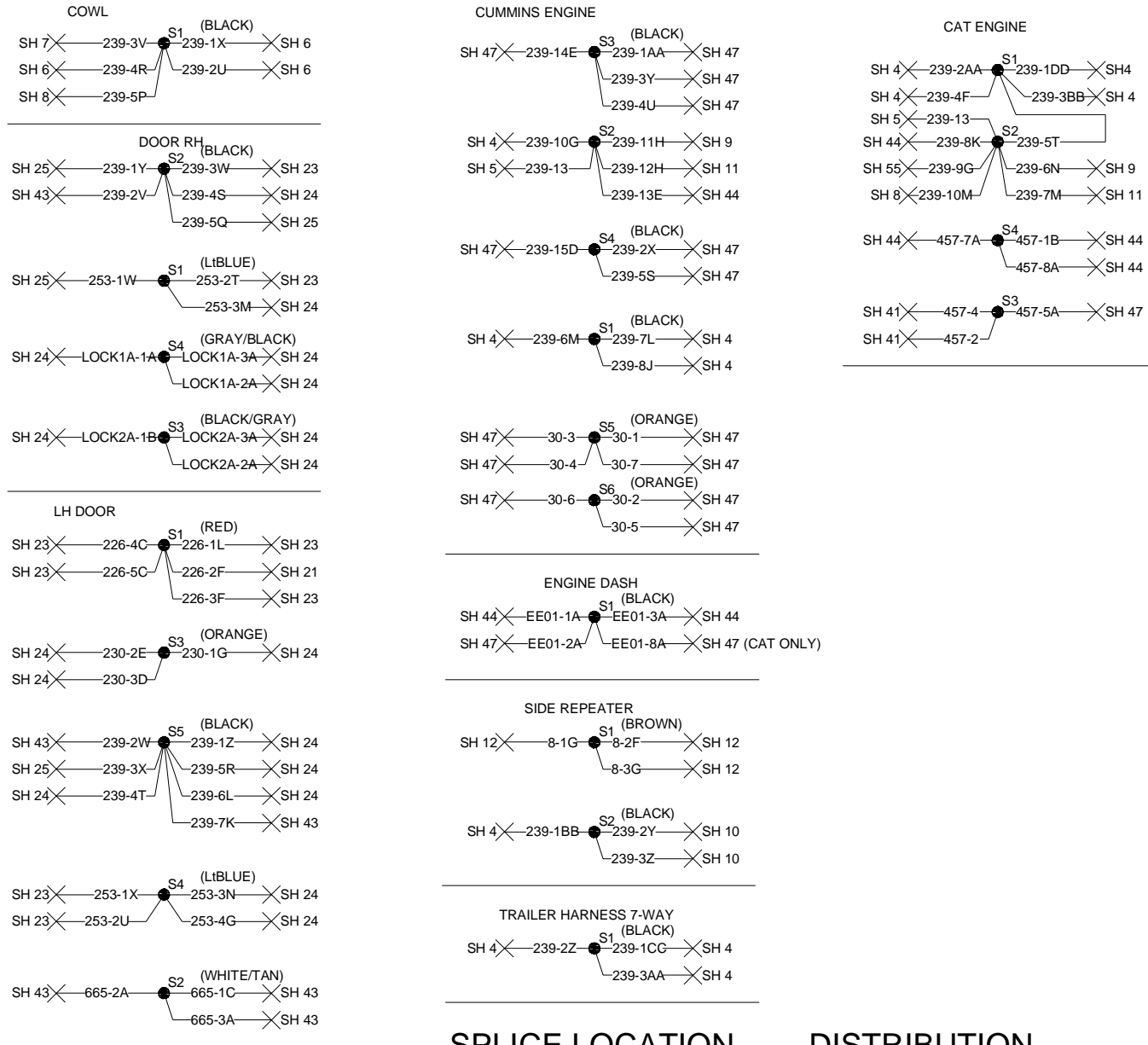

SPLICE LOCATION

DISTRIBUTION

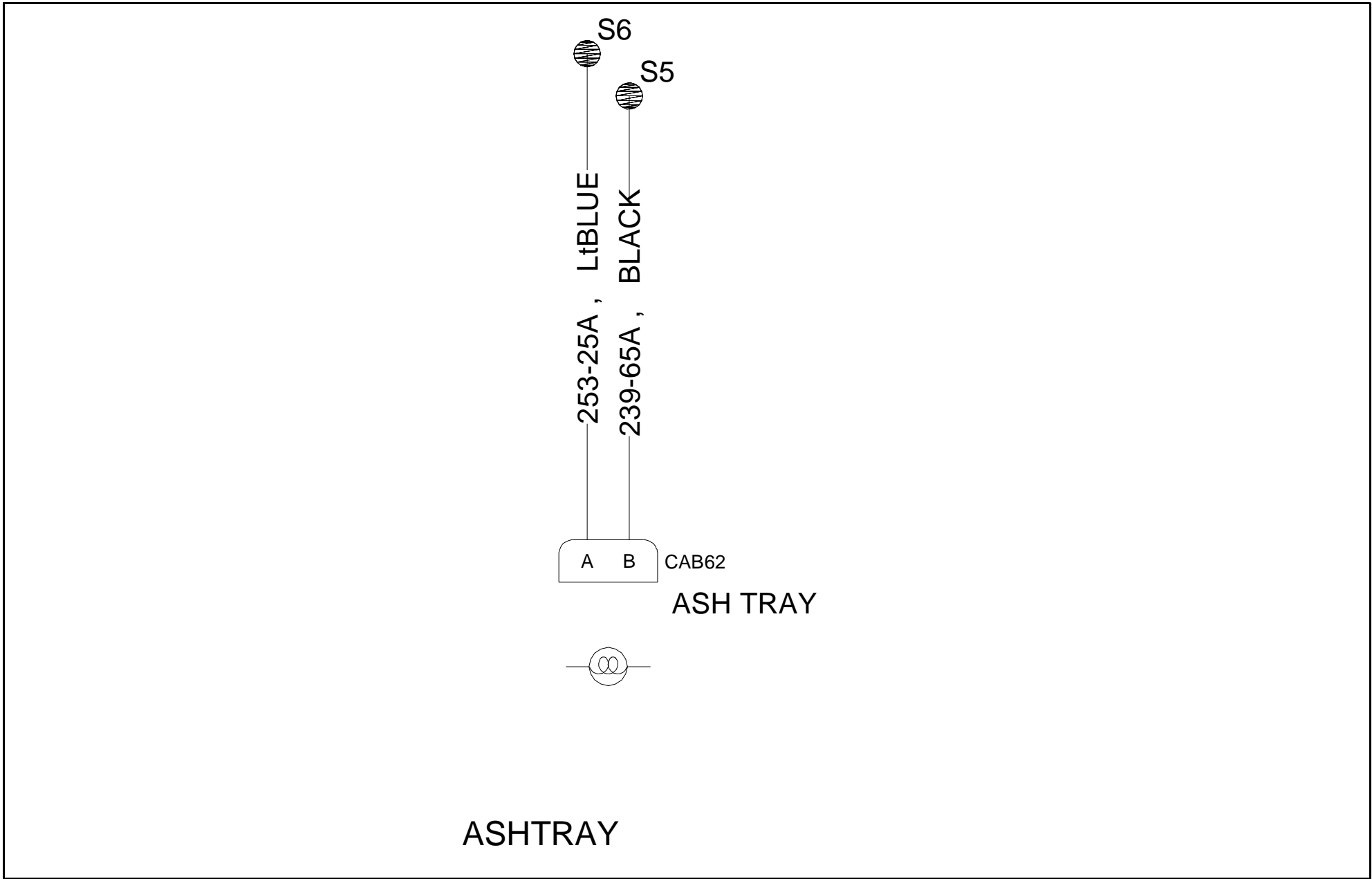

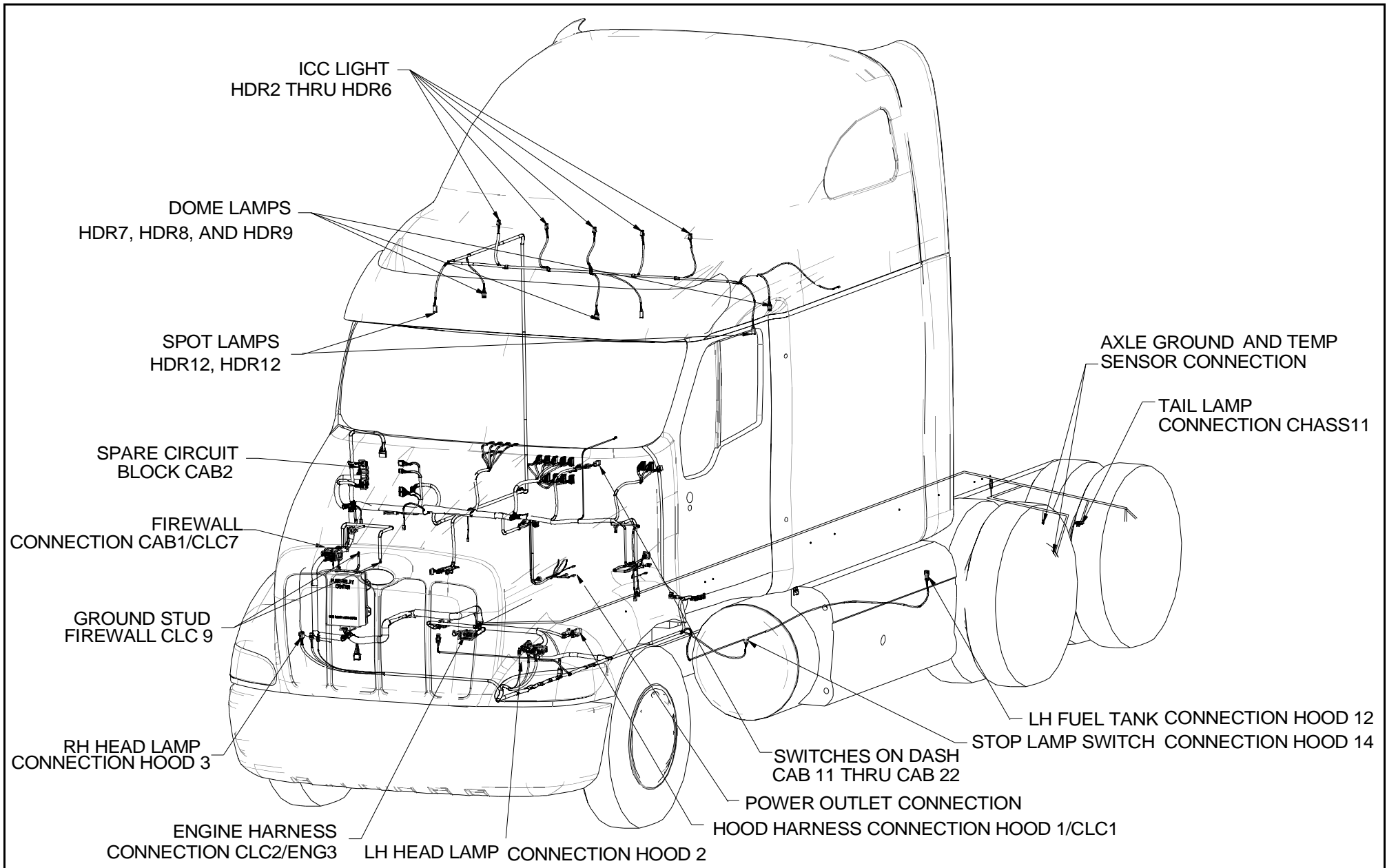

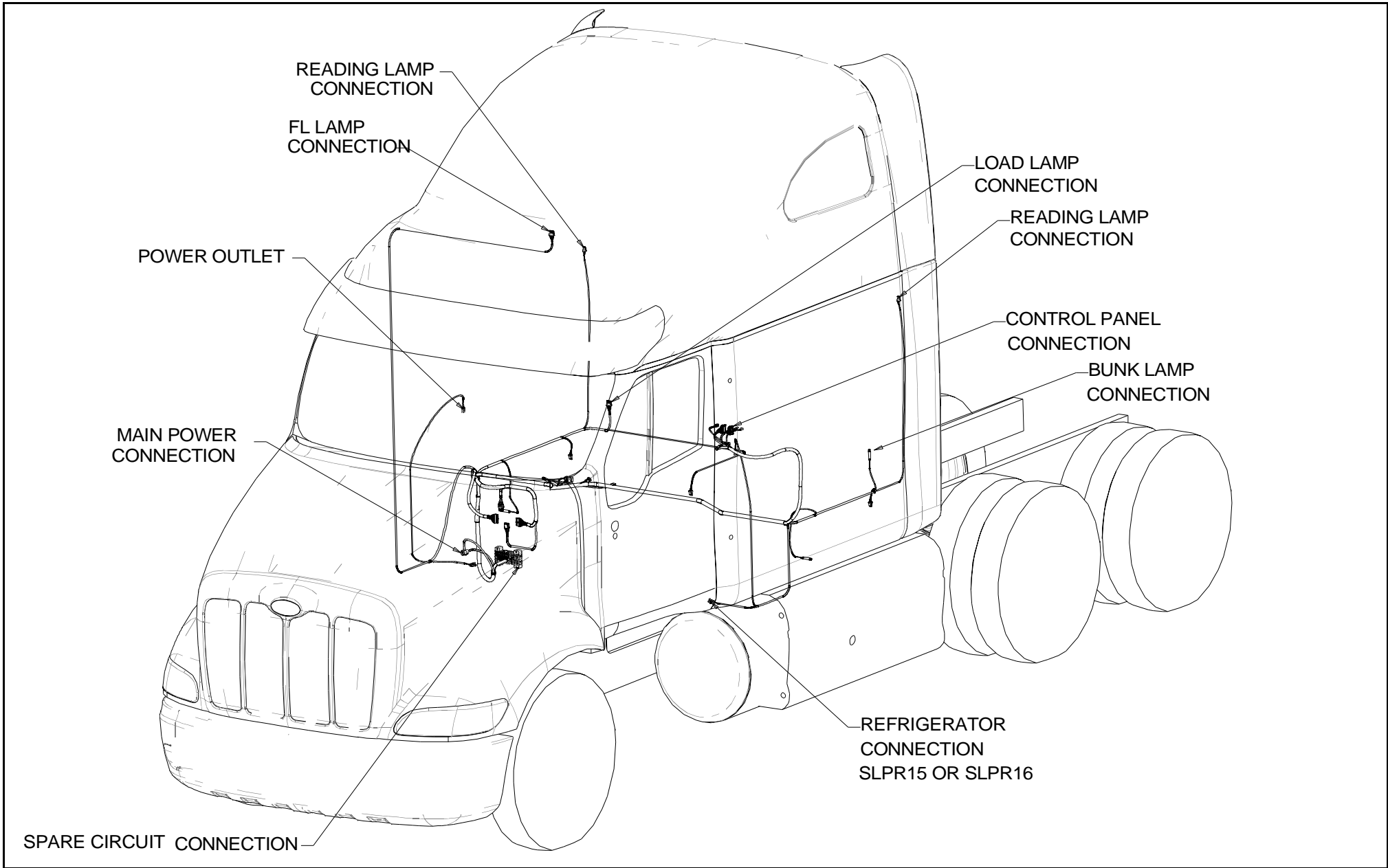

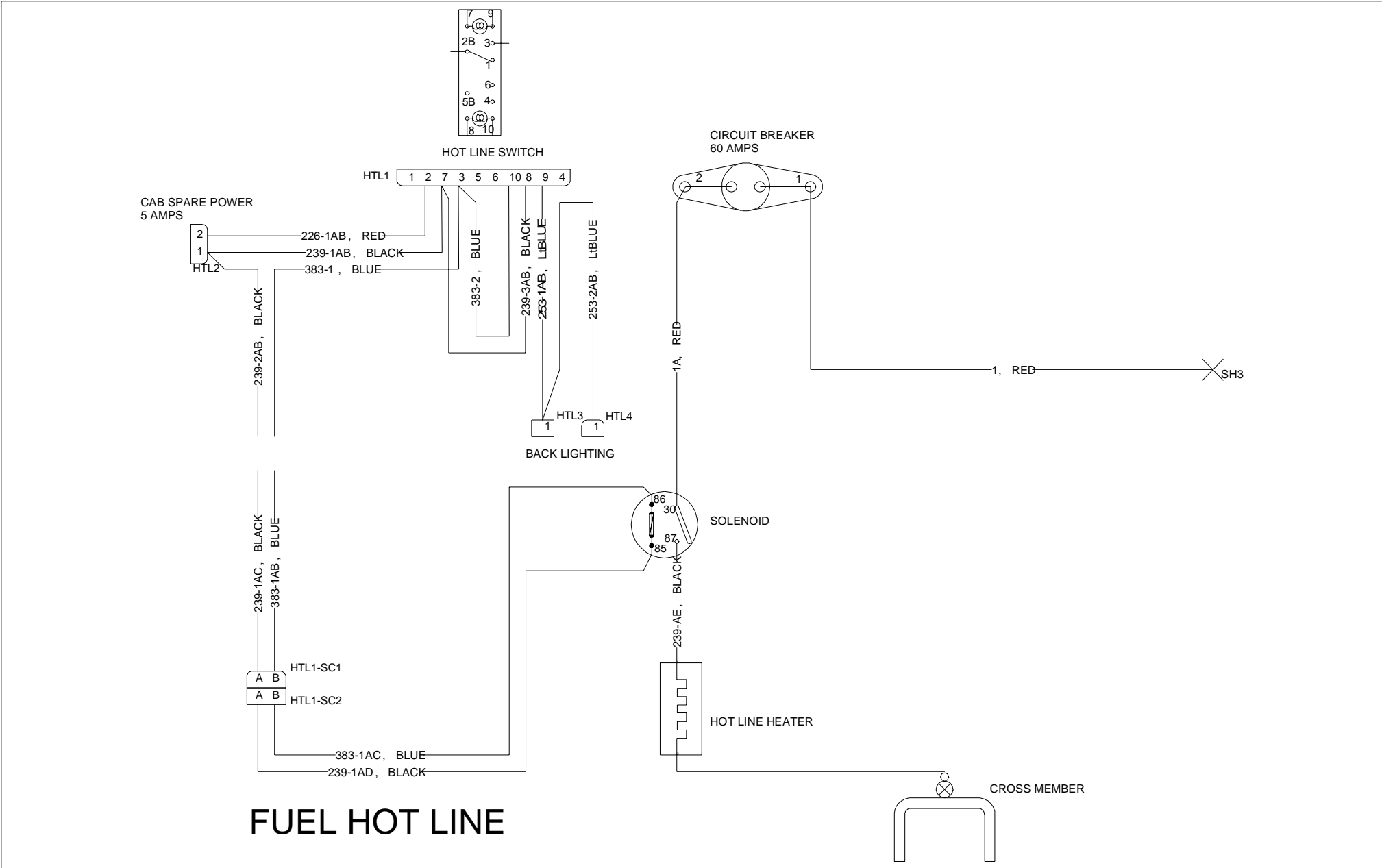

FUEL HOT LINE

