

# Roadranger®

## Dana® Spicer® Heavy Tandem Drive Axles

D40-170, D40-170DP, D40-170P, D46-170, D46-170DP,  
D46-170H, D46-170HP, D46-170P, D52-190D, D52-190, D60-190,  
R40-170, R46-170, R52-190, R60-190,  
D46-590HP, D52-590, D60-590, D70-590,  
R46-590, R52-590, R60-590, R70-590



One Great Drivetrain from Two Great Companies

Illustrated Parts List AXIP-0057 December 2005

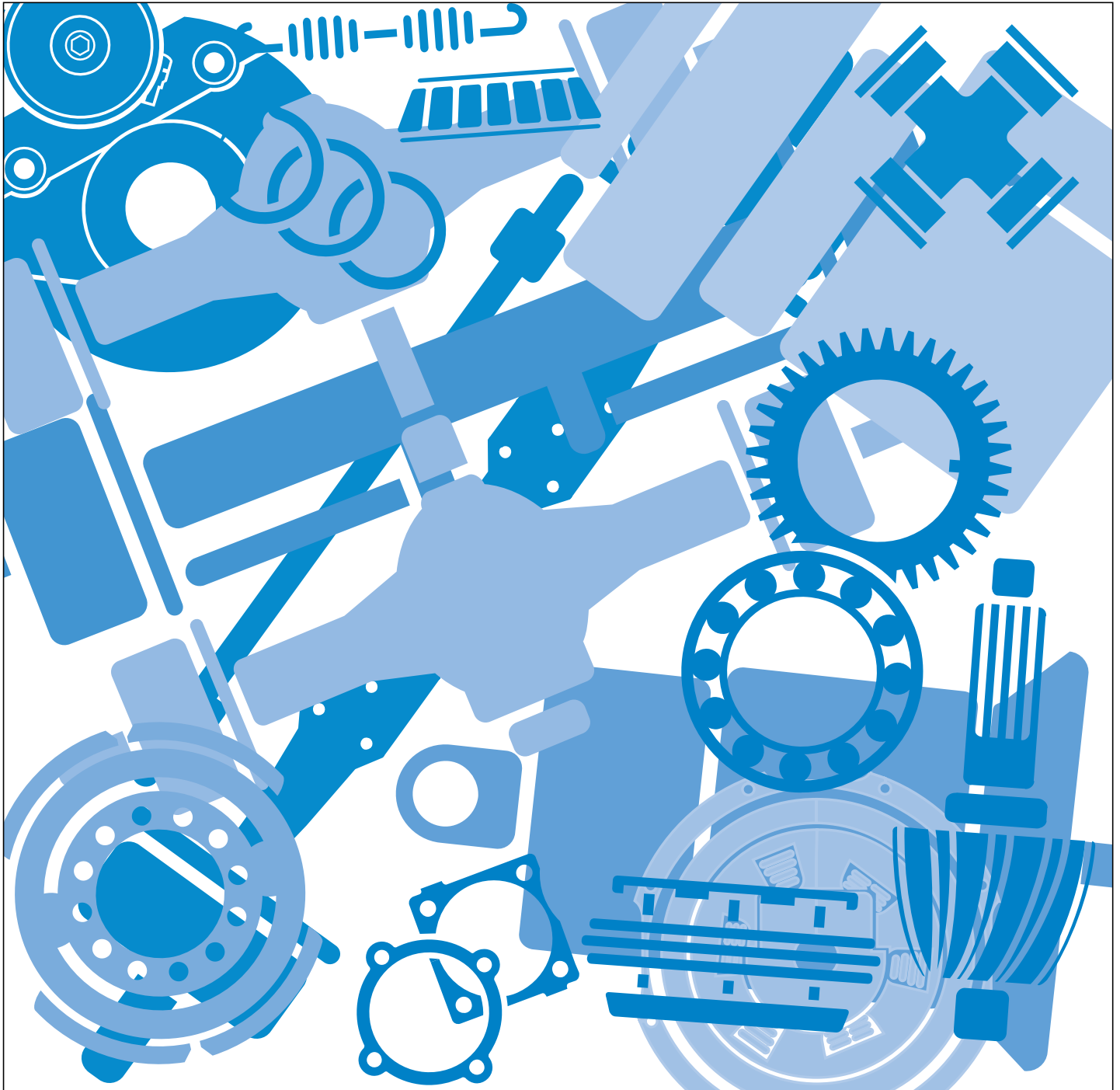

For the most current information, visit the Roadranger web site at [www.roadranger.com](http://www.roadranger.com)



**TABLE OF CONTENTS**

**Model Information** ..... 2  
     Single Reduction Model.....2  
     Helical Reduction Models .....2  
**How To Use Illustrated Parts List** ..... 3  
**Model Identification** ..... 4  
**D170 / D190 Heavy Tandem Axle - Parts Exploded View** ..... 6  
**Power Divider - Parts Exploded View**..... 7  
**D170 / D190 Heavy Tandem Axle - Parts List** ..... 8  
**Spicer Wheel Differential Case Kits** .....10  
**R170 / R190, S170 / S190 Heavy Tandem Axle - Parts Exploded View**...11  
**R170 / R190, S170 / S190 Heavy Tandem Axle - Parts List** .....12  
**Wheel Differential Lock - All Models** ..... 14  
**Housing and Output Shaft Assembly - Parts Exploded View** .....15  
**Housing and Output Shaft Assembly - Parts List**.....16  
     Summary of Kits & Assemblies .....16  
**Axle Housing Hardware Kit Listing**.....17  
**Axle Shafts**.....18  
**Yokes & Flanges** ..... 19  
**Service Kits**.....20  
     Seal Driver Kit.....20  
     Wheel Differential Bearing Adjustment Kit .....20  
**Bearing Kits**.....21  
**Bearing Spacers** .....22  
**New Service Carriers**.....23  
**Spicer Service Kits Parts Listing** .....27

## Model Information

The following models are included in this publication:

### Single Reduction Model

Forward Axle	Rear Axle	Axle Capacity	Gear Size
D40-170	R40-170	40,000 lbs.	18" Hypoid Gear
D40-170DP	R40-170	40,000 lbs.	18" Hypoid Gear
D40-170P	R40-170	40,000 lbs.	18" Hypoid Gear
D46-170	R46-170	46,000 lbs.	18" Hypoid Gear
D46-170DP	R46-170	46,000 lbs.	18" Hypoid Gear
D46-170H	R46-170	46,000 lbs.	18" Hypoid Gear
D46-170HP	R46-170	46,000 lbs.	18" Hypoid Gear
D46-170P	R46-170	46,000 lbs.	18" Hypoid Gear
D52-190DP	R52-190	52,000 lbs.	18.5" Hypoid Gear
D52-190P	R52-190	52,000 lbs.	18.5" Hypoid Gear
D60-190P	R60-190	60,000 lbs.	18.5" Hypoid Gear

### Helical Reduction Models

Forward Axle	Rear Axle	Axle Capacity	Gear Size
D46-590HP	R46-590	46,000 lbs.	18.5" Hypoid Gear
D52-590P	R52-590	52,000 lbs.	18.5" Hypoid Gear
D60-590P	R60-590	60,000 lbs.	18.5" Hypoid Gear
D70-590P	R70-590	70,000 lbs.	18.5" Hypoid Gear

The suffix letter "P" in the model number indicates lube pump. The pump is designed to provide additional lubrication to the inter-axle differential and related parts. The "190" and "590" models come standard with pumps and the suffix letter "P" may not be referenced in all model callouts.

**Note:** At the time of this revision, the "590" Series parts have not been added to the IPL. Contact your Roadranger representative for assistance.

## How To Use Illustrated Parts List

### Ordering Parts

- This parts book is organized in sections according to parts servicing requirements. Use the Contents or page headings and colored tabs to find information.
- Use this book to order parts for your Dana® Spicer® Axle.
- For convenience, part numbers have been included for all pieces of the carrier assembly. Some of these parts, such as the carrier and caps, are serviced only in kits or assemblies. Part numbers are for your reference only. Those parts not serviced separately are identified with NSS.

### Kits and Assemblies

- Kits and Assemblies contain groups of individual or assembled parts developed for optimal replacement or repair of a service problem.
- Kits and Assemblies are shown with applicable parts groupings in the parts listing.
- See the Appendix for detailed information concerning kits applicable to this model.

### Abbreviations

- **AR - As Required** - Parts that vary in quantity with each axle. Example: shims
- **NSS - Not Serviced Separately** - Items which can only be purchased in sets, kit form or service assemblies. Example: brake shoes.
- **RH/LH - Right Hand/Left Hand** - Determined as viewed from behind the vehicle looking forward.
- **“RTV” - Gasket Compound** - Formed-in-place gasket sealer. It is recommended for use on all surfaces requiring a gasket.
- **Assy - Assembly**
- **Brg - Bearing**
- **Diff - Differential**
- **Hsg - Housing**
- **Inv - Involute**
- **IASS - In Axle Speed Sensor**
- **ABS - Antilock Brake System**
- **N/A - Not Applicable**
- **Str - Straight**

### Illustrations

- Illustrations show parts in assembly groups.
- Item numbers on illustrations correspond with parts listings on pages that accompany the drawings.
- Notes are included on illustrations where needed.

### Parts Listings

- Parts listings are defined by parts groupings and are broken down by service assemblies.
- Parts Listings identify a part for servicing with the following categories:
  - **Item** - corresponds with numbers on illustrations for part identification
  - **Description** - specifies part name or description
  - **Quantity (Qty)** - quantity required for assembly
  - **Current Part** - service part numbers are broken down by model, type or other applicable information
  - **Notes** - define unique characteristics or replacement notes
  - **Kits / Assy's Where Used** - indicates Kits or Assemblies that contain a particular part

\* Other pertinent information is listed in tables or parts listings as required.

### Effectively using a parts listing—Example

- Follow the example below to locate and order exactly what is required for servicing.

Match to items on illustration	Use to identify Part	Order this quantity for servicing	Order Part Number by Model indicated		Indicates information important to ordering or use
Item	Description	Qty	D170	D190(P)	Notes
1	Axle Shaft	2			See Axle Shaft Chart
2	Flat Washer	4			

## Model Identification

### Drive Axle

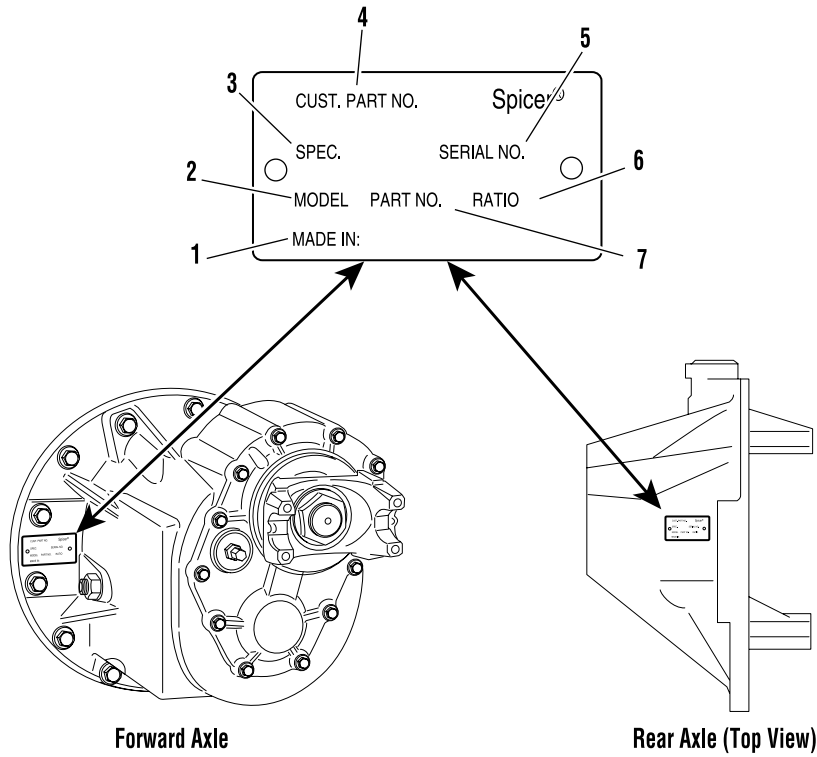

**1 - Country or origin**

**2 - Axle model identification**

**3 - Specification number assigned to the axle built by Dana. Identifies all component parts of the axle including special OEM requirements such as yokes or flanges.**

**4 - OEM part number assigned to the axle build**

**5 - Carrier assembly serial number assigned by the manufacturing plant**

**6 - Axle gear ratio**

**7 - Carrier assembly production or service part number**

**Axle Housing**

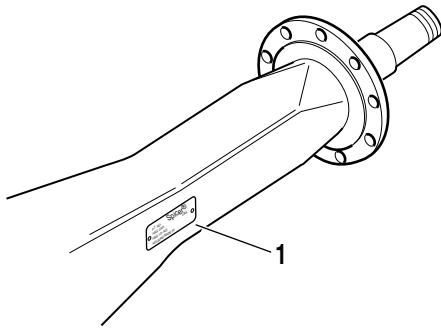

**1 - ID Tag**

**Axle Shaft**

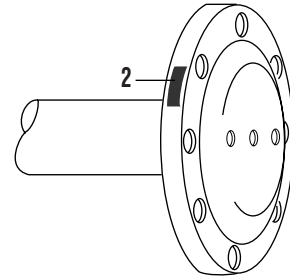

**2 - Axle shaft part number**

**Using Model Designation to Identify Axle Components**

- The Axle Model Identification number contains information that is important to understand when purchasing service parts or new components. The Model Identification number provides important vehicle, capacity and application information and model features. Use this guideline to understand your Axle Model Identification. If you need assistance, contact your Roadranger representative.

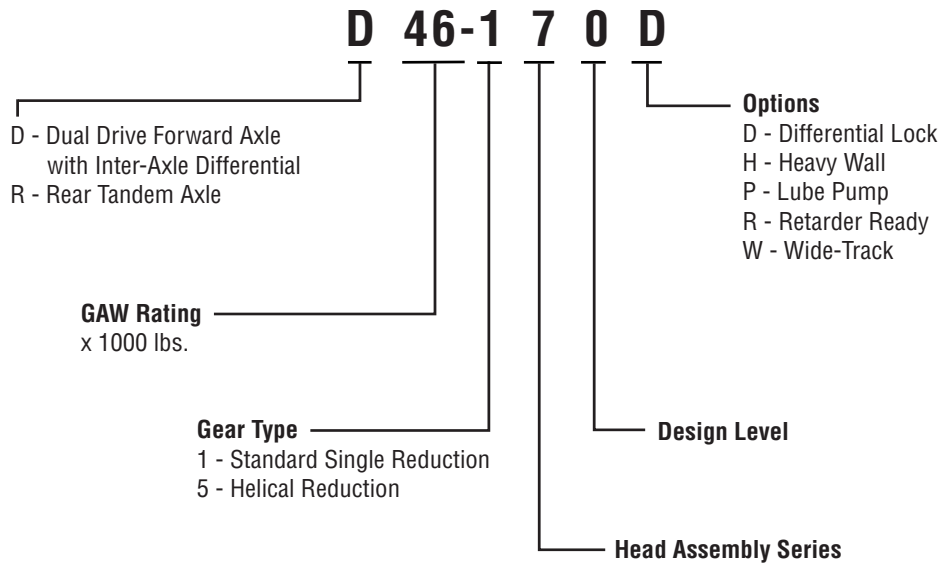

### D170 / D190 Heavy Tandem Axle - Parts Exploded View

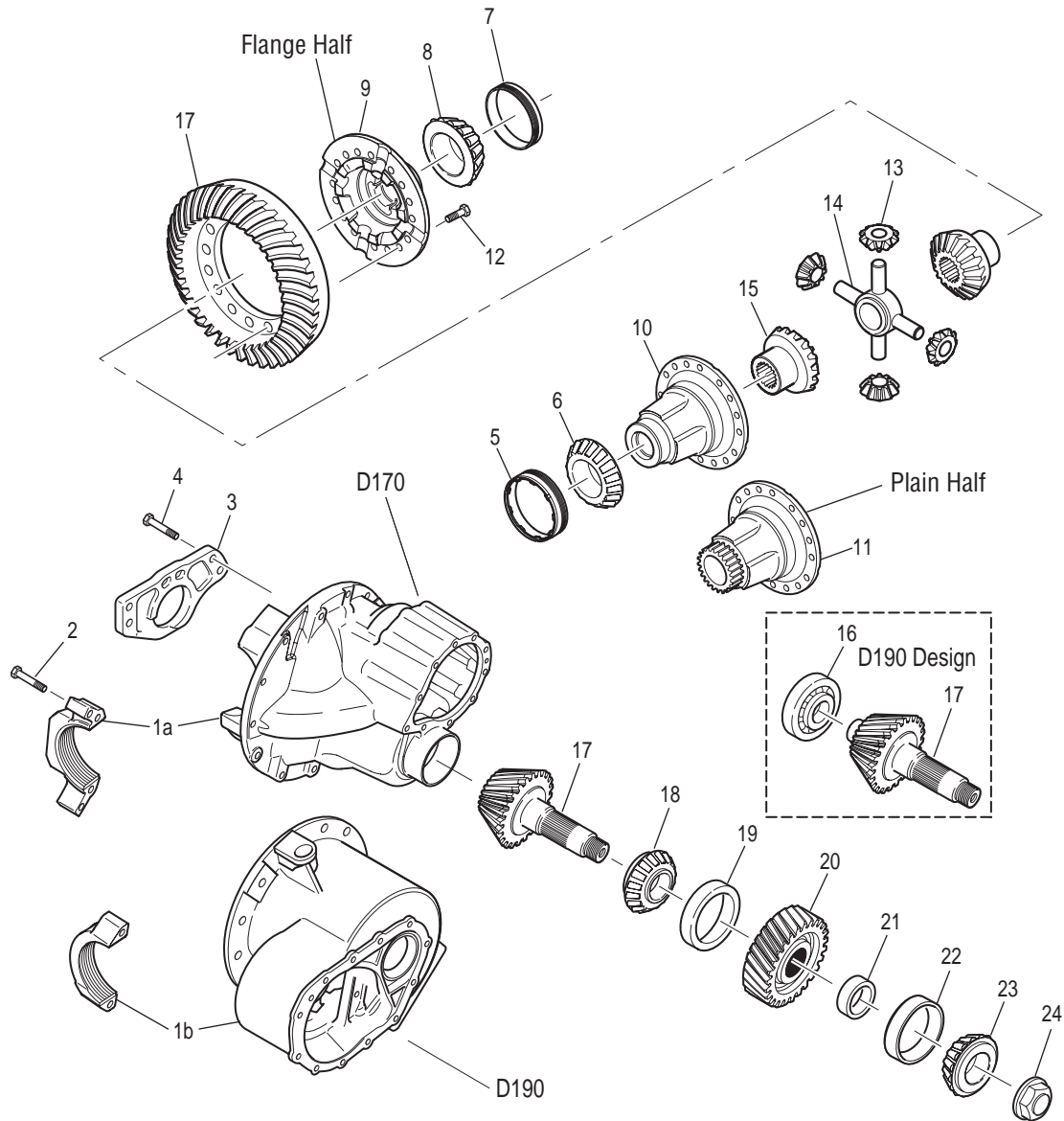

Parts for  
Diff Lock Assembly  
See page 14



### Power Divider - Parts Exploded View

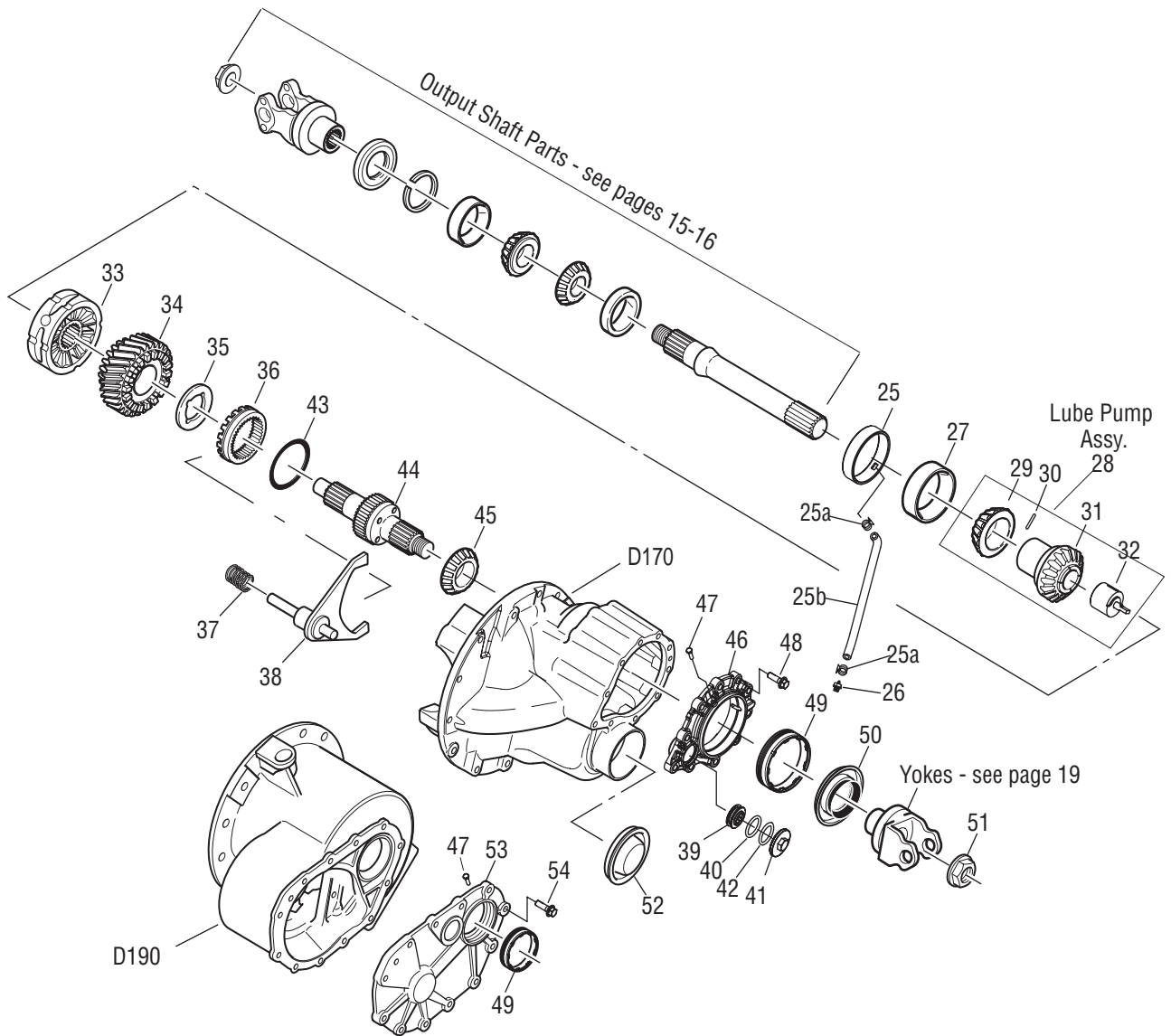

## D170 / D190 Heavy Tandem Axle - Parts List

Item	Description	Qty Per Axle	D170 D170D	D190 D190D	Notes	
<b>Bearing Kits</b>		<b>1</b>	<b>N/A</b>	<b>514012</b>	<b>All Models</b>	
<b>Contents identified with *</b>		<b>1</b>	<b>514238</b>	<b>N/A</b>	<b>D170 Models Only</b>	
		<b>1</b>	<b>514011</b>	<b>N/A</b>	<b>Diff Lock Models Only</b>	
1a	Diff Carrier & Bearing Caps - NSS	1	See Page 9		D170 Series	
1b	Diff Carrier & Bearing Caps - NSS	1	See Page 9		D190 Series	
2	Bearing Cap Capscrew	6	131016	131016		
3	Pilot Bearing Web Support - NSS	1	Note 1	N/A	Not a serviceable part - order item 1	
4	Pilot Bearing Web Capscrews	4	Note 1	131017		
5	Threaded Diff Bearing Cup - Plain Half	1	131044*	131048*	Standard Models	
		1	131048*	131048*	Diff Lock Models	
6	Diff Bearing Cone - Plain Half	1	131041*	131042*	Standard Models	
		1	131042*	131042*	Diff Lock Models	
7	Threaded Diff Bearing Cup - Flange Half	1	131044*	131044*	All Models	
8	Diff Bearing Cone - Flange Half	1	131041*	131041*	All Models	
9	Diff Case - Flange Half	1	See Kits Page 14			
10	Diff Case - Plain Half	1	See Kits Page 14		Standard Models	
11	Diff Case - Plain Half	1	See Kits Page 14		Diff Lock Models	
12	Bolt - Ring Gear	16	131473	131473		
<b>Wheel Diff Kit</b>			<b>513868</b>	<b>513868</b>	<b>Includes items 13-15</b>	
13	Side Pinion	4	131040	131040		
14	Spider	1	131039	131039		
15	Diff Side Gear	2	300GD101	300GD101	46 Inv Spline	
16	Pinion Pilot Bearing	1	129947*	129947*		
17	Ring Gear and Pinion - NSS		See Kits Page 27			
18	Pinion Bearing Cone - Inner	1	131050*	131050*		
19	Pinion Bearing Cup - Inner	1	131051*	131051*		
20	Pinion Helical Gear	1	131343	131343		
21	Pinion Bearing Spacer	A/R			See page 21	
22	Pinion Bearing Cup - Outer	1	131203*	131203*		
23	Pinion Bearing Cone - Outer	1	131202*	131202*		
24	Pinion Nut - 131095* - NSS	1	131095K*	131095K*	Must order 131095K	
<b>Manifold Parts Kit</b>						
<b>Pump Models</b>		<b>1</b>	<b>513878</b>	<b>513878</b>	<b>Includes items 25-26</b>	
<b>Non-Pump Model</b>		<b>1</b>	<b>513880</b>	<b>N/A</b>	<b>Includes item 25</b>	
25	Manifold Assembly - NSS	1	131366-NSS	131366-NSS	Used in Pump Models only	
		1	131367-NSS	N/A	Non-Pump Models	
25a	Clamp	2	129338	129338		
25b	Hose	1	131524	131524		
26	Screen Filter Assembly	1	131370	131370		
27	Output Side Gear Bearing Cup	1	131209*	131209*		
<b>28</b>	<b>Lube Pump Kit</b>	<b>1</b>	<b>513876</b>	<b>513876</b>	<b>Includes items 29-32</b>	
29	Output Side Gear Bearing Cone	1	131208*	131208*		
30	Pin	1	131541	131541	Included in kit was #131369	
31	Output Side Gear	Non-Pump	1	131467	N/A	
		Pump	1	131466	131466	
32	Pump - Lube - NSS	1	131368-NSS	131368-NSS	Order Lube Pump Kit	

Item	Description	Qty Per Axle	D170 D170D	D190 D190D	Notes
33	Inter-Axle Differential	1	131339	131339	
34	Helical Side Gear & Bushing Assembly	1	131345	131345	Side Gear #131005-NSS
35	Thrust Washer	1	131354*	131354*	
36	Sliding Clutch	1	131332	131332	
	<b>Shift Fork &amp; Spring Kit</b>	<b>1</b>	<b>510870</b>	<b>514142</b>	<b>Includes items 37-38</b>
37	Compression Spring	1	129859	129859	
38	Shift Fork Assembly - NSS	1	129856	131330	Order kit above
	<b>Air Lockout Repair Kit</b>	<b>1</b>	<b>512892</b>	<b>512892</b>	<b>Includes items 39-42</b>
	<b>Air Lockout Kit (Complete w/Shift Fork)</b>	<b>1</b>	<b>512893</b>	<b>N/A</b>	<b>Includes items 37-42</b>
39	Piston	1	131232	131232	
40	O-Ring - Piston	1	210180	210180	
41	Piston Cover	1	131096	131096	
42	O-Ring Cover	1	131665	131665	Replaces 131496
43	V-ring	1	131333*	131333*	
<b>44</b>	<b>Input Shaft Kit - Non Pump Model</b>	<b>1</b>	<b>513839</b>	<b>N/A</b>	<b>Shaft #131348, includes items 44, 51, &amp; 55</b>
	<b>Input Shaft Kit - Pump Model</b>	<b>1</b>	<b>513840</b>	<b>513840</b>	<b>Shaft #131349, includes items 44, 51, &amp; 55</b>
45	Input Shaft Bearing Cone	1	131205*	131205*	
<b>46</b>	<b>Input Cover Kit</b>	<b>1</b>	<b>513881</b>	<b>N/A</b>	<b>Cover part #131221-NSS, includes items 46-48</b>
47	Locking Capscrew	1	131373	131373	
48	Capscrew - Input Cover	10	131374	N/A	
49	Input Adjuster & Cup Assembly	1	131217	131217	Includes Cup #131206*
50	Input Seal - 131008*-NSS	1	131008K*	131008K*	Includes items 51 & 55
51	Input Nut - 131095*-NSS	1	131095K*	131095K*	Includes item 55
52	Pinion Cover	1	131224	N/A	
<b>53</b>	<b>Input Cover Kit</b>	<b>1</b>	<b>N/A</b>	<b>513879</b>	<b>Cover part #131328-NSS, includes items 47, 53-54</b>
54	Capscrew - Input Cover	12	N/A	131374	
55	Loctite	1	129293*	129293*	
56	RTV Sealant	1	107276S*	107276S*	

**Diff Carrier & Bearing Cap Kits**

Item	Model	Part No.	Notes
1a	D170	513997	Includes items 1a, 2
1a	D170D	513998	Includes items 1a, 2
1b	D190, D190D	514001	Includes items 1b, 2-4

Carrier/Cap Identification Information:

Part No.	Notes
131223	No Pilot Web order 513997
131219	No Pilot Web order 513998
131325	Built w/Pilot Web order 514001

To convert D170 Non-Pump Models to Pump Option, order:

- 1 - 513840 I/P Kit
- 1 - 513876 Lube Pump Kit
- 1 - 513878 Manifold Kit

## Spicer Wheel Differential Case Kits

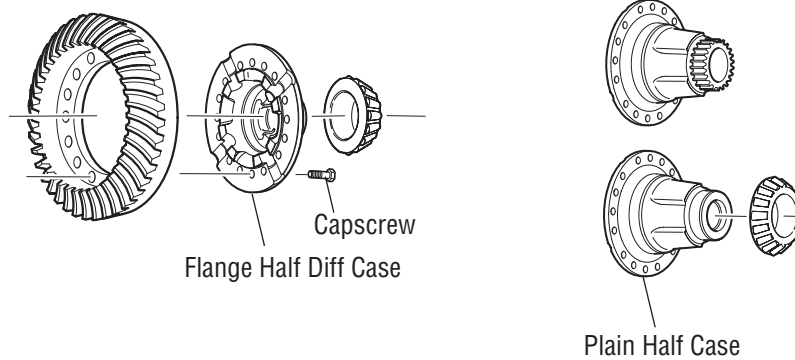

Shown below are the service kit part numbers and individual contents. In some cases customers may only require the flange half or plain half for various reasons. All parts are available individually too.

### 170 SERIES

Ratio	Wheel Diff Case Kit P/N	Flange Half	Plain Half	Capscrew Qty 16
<b>S170, S170NS, R170, R170NS</b>				
2.69-3.07	513986	131027	131479	131473
3.21	513987	131027	131478	131473
3.31-7.17	513988	131029	131478	131473
<b>S170D</b>				
2.69-3.07	513989	131027	131477	131473
3.21	513990	131027	131476	131473
3.31-7.17	513991	131029	131476	131473
<b>D170, D170NS</b>				
3.07-3.31	513986	131027	131479	131473
3.42-7.17	513988	131029	131478	131473
<b>D170D</b>				
3.07-3.31	513989	131027	131477	131473
3.42-7.17	513991	131029	131476	131473

### 190 SERIES

Ratio	Wheel Diff Case Kit P/N	Flange Half	Plain Half	Capscrew Qty 16
<b>S190*, S190NS*, S190D, R190*, R190NS*, R190D</b>				
2.53-3.21	513989	131027	131477	131473
3.42-3.58	513990	131027	131476	131473
3.31, 3.73-7.83	513991	131029	131476	131473
<b>D190*, D190NS*, D190D</b>				
3.42-7.17	513991	131029	131476	131473

NS = No Spin

\* Single Speed models built w/ the splined diff lock design case in production

R170 / R190, S170 / S190 Heavy Tandem Axle - Parts Exploded View

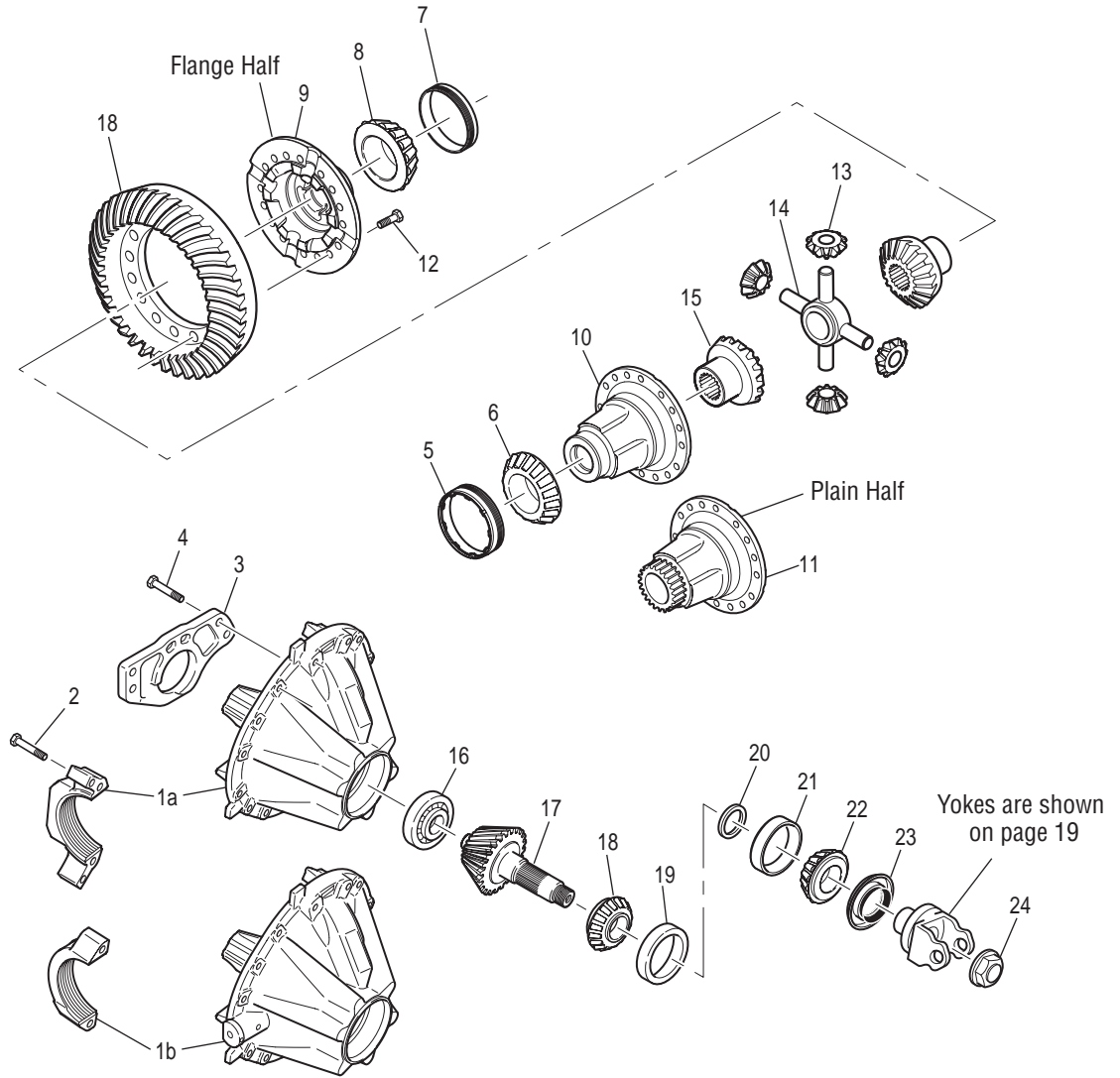

Parts for Diff Lock are shown on page 14

## R170 / R190, S170 / S190 Heavy Tandem Axle - Parts List

Item	Description	Qty Per Axle	S170 S170D R170 R170D	S190 S190D R190 R190D	Notes
<b>Bearing Kits</b>		<b>1</b>	<b>N/A</b>	<b>514015</b>	<b>Ratios 2.53-4.78 only</b>
<b>Contents Identified with *</b>		<b>1</b>	<b>N/A</b>	<b>514016</b>	<b>Ratios 5.25-7.83 only</b>
		<b>1</b>	<b>514013</b>	<b>N/A</b>	<b>Standard Models 2.69-3.91</b>
		<b>1</b>	<b>514014</b>	<b>N/A</b>	<b>Standard Models 4.10-7.17</b>
		<b>1</b>	<b>514239</b>	<b>N/A</b>	<b>Diff Lock Models 2.69-3.91</b>
		<b>1</b>	<b>514240</b>	<b>N/A</b>	<b>Diff Lock Models 4.10-7.17</b>
1a	Diff Carrier & Bearing Caps	1	See Page 13		Standard Models
1b	Diff Carrier & Bearing Caps	1	See Page 13		Diff Lock Models
2	Bearing Cap Capscrew	6	131016	131016	
3	Pilot Bearing Web Support	1	Note 1	NSS	Not a serviceable part
4	Pilot Bearing Web Capscrews	4	Note 1	131017	
5	Threaded Diff Bearing Cup - Plain Half	1	131044*	131048*	Standard Models
		1	131048*	131048*	Diff Lock Models
6	Diff Bearing Cone - Plain Half	1	131041*	131042*	Standard Models
		1	131042*	131042*	Diff Lock Models
7	Threaded Diff Bearing Cup - Flange Half	1	131044*	131044*	All Models
8	Diff Bearing Cone - Flange Half	1	131041*	131041*	All Models
9	Diff Case - Flange Half	1	See Kits Page 14		
10	Diff Case - Plain Half	1	See Kits Page 14		
11	Diff Case - Plain Half	1	See Kits Page 14		
12	Ring Gear Bolt	16	131473	131473	
<b>Wheel Diff Kit</b>			<b>513868</b>	<b>513868</b>	<b>Includes items 13-15</b>
13	Side Pinion	4	131040	131040	
14	Spider	1	131039	131039	
15	Diff Side Gear	2	300GD101	300GD101	46 Involute
16	Pinion Pilot Bearing	Ratios 2.69 - 3.91	1	129947*	N/A
		Ratios 2.53 - 4.78	1	N/A	129947*
		Ratios 5.25 - 7.83	1	N/A	126187*
17	Ring Gear & Drive Pinion Set		See Kits Page 27		
18	Pinion Bearing Cone (Inner)	1	131050*	131050*	
19	Pinion Bearing Cup (Inner)	1	131051*	131051*	
20	Pinion Bearing Spacer	A/R	- - -	- - -	See Page 22
21	Pinion Bearing Cup (Outer)	1	131051*	131051*	
22	Pinion Bearing Cone (Outer)	1	131052*	131052*	
23	Pinion Oil Seal - 131008*-NSS	1	131008K*	131008K*	
24	Pinion Flanged Nut - 131095*-NSS	1	131095K*	131095K*	
25	RTV Sealant	1	107276S*	107276S*	Not illustrated

**Diff Carrier & Bearing Cap Kits**

**Note:** Some 170 Series models utilize the Pilot Web, while others are the overhung design (no Pilot Web). All service replacement carrier/cap kits include the Pilot Web design.

Item	Model	Part No.	Notes
1a	R170, S170	513999	Includes items 1a, 2-4
1b	R170D, S170D	514000	Includes items 1b, 2-4
1b	R190, S190D, R190D, S190D	514002	Includes items 1b, 2-4

Carrier/Cap Identification Information:

Part No.	Notes
131019-NSS	Built w/Pilot Web order 513999
131021-NSS	Built w/Pilot Web order 514000
131025-NSS	Built w/Pilot Web order 514002
131229-NSS	No Pilot Web order 513999
131231-NSS	No Pilot Web order 514000

## Wheel Differential Lock - All Models

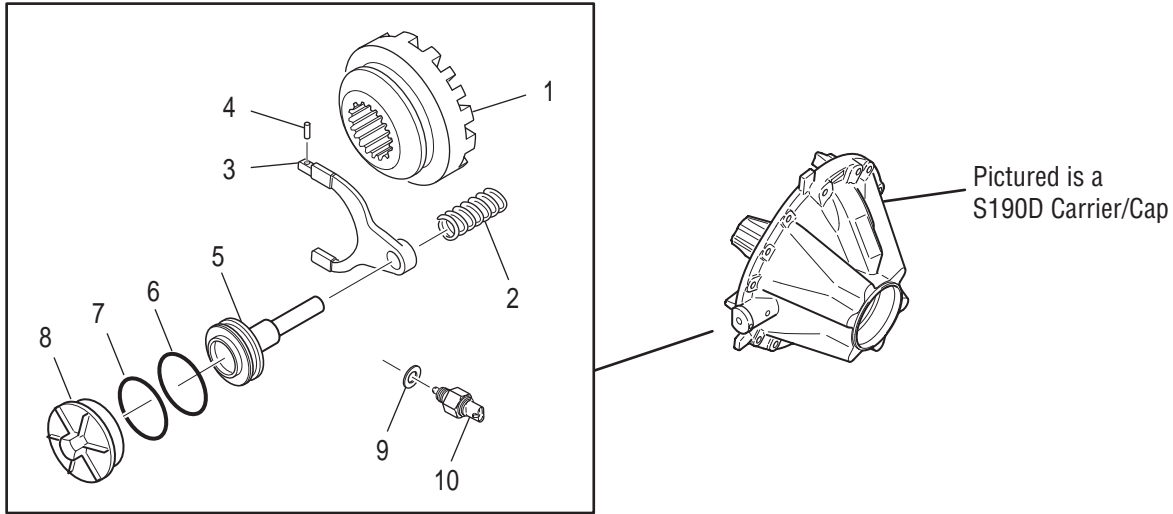

WHEEL DIFFERENTIAL LOCK ASSEMBLY

Item	Description	Qty	D/R170 D/R190 S170 S190	Notes
<b>Diff Lock Conversion Kit - 190 Series only</b>				<b>Note 1</b>
	<b>Ratios 3.07, 3.20, and 3.91-7.17</b>		<b>512946</b>	<b>Includes items 1-10 and 512944</b>
	<b>Ratios 2.53-2.93 and 3.31-3.73</b>		<b>512947</b>	<b>Includes items 1-10 and 512945</b>
<b>Diff Lock Repair Kit</b>				<b>512895</b>
1	Sliding Clutch	1	131104	
2	Spring	1	131102	
3	Shift Fork Assy	1		
			Ratios 3.07, 3.21 and 3.91-7.17	512944 Shift Fork 131099 NSS; includes item 4
			Ratios 2.53-2.93 and 3.42-3.73	512945 Shift Fork 131101 NSS; includes item 4
4	Pin	1	210020	
5	Piston & Rod Assembly	1	131237	
6	O-Ring - Piston	1	210180	
7	O-Ring - Cap Cover	1	131496	was 220HH102
8	Piston Cover (Diff Lock Cap)	1	131096	
9	Washer	1	129034	
10	Switch	1	129035	

**Note 1:** The “170” Series axles cannot be converted to Diff Lock. You must have the base carrier/cap that has the Diff Lock shift cylinder. All “190” Series have the shift cylinder as a standard design.



### Housing and Output Shaft Assembly - Parts Exploded View

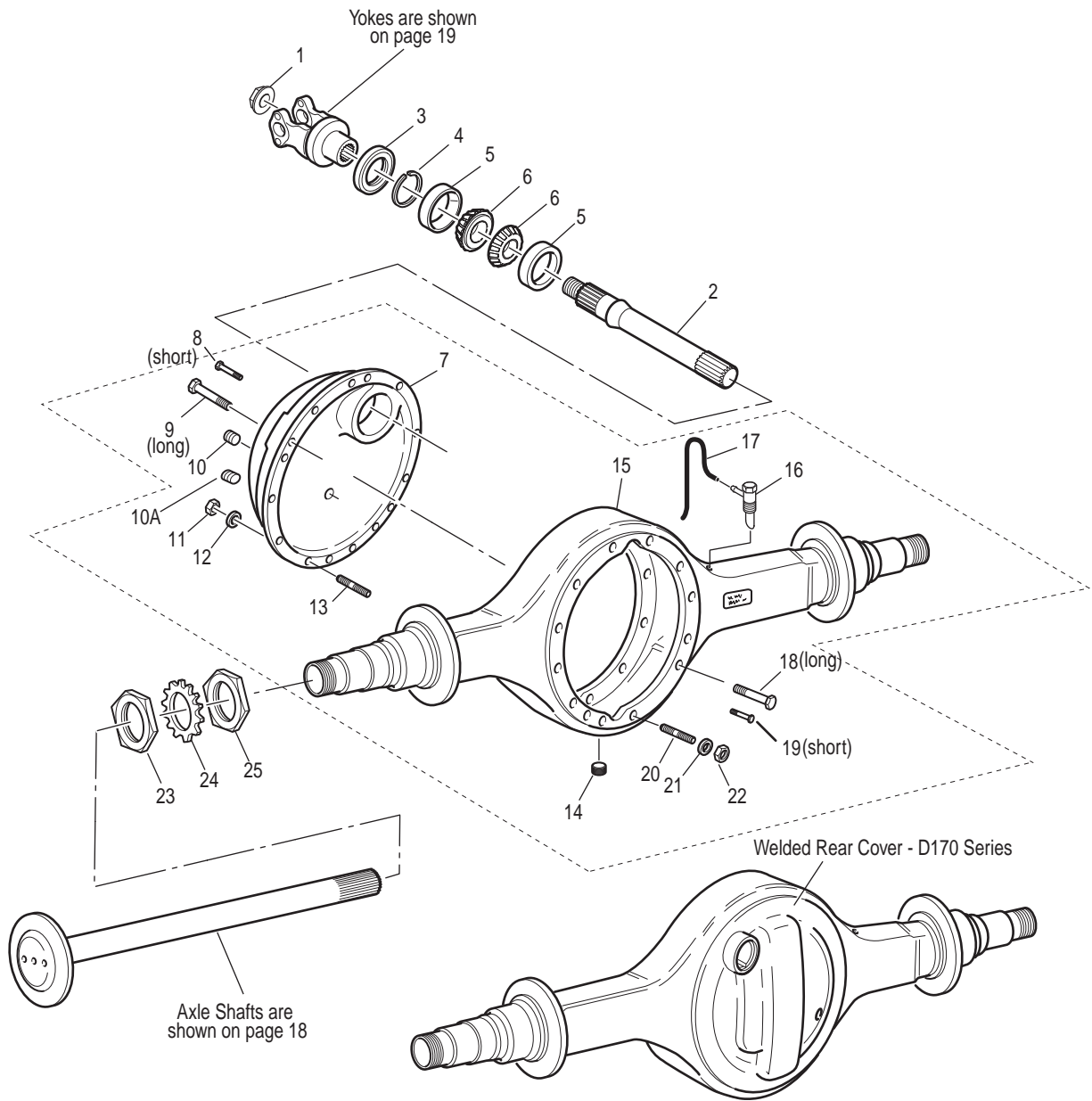

## Housing and Output Shaft Assembly - Parts List

Item	Description	Qty	All Models	Notes
1	Output Shaft Nut	1	128049	
	<b>Output Shaft Kit</b>	<b>1</b>	<b>512894</b>	<b>See Note 1</b>
2	Output Shaft - 131536-NSS	1	Order Kit	Replaces #131468 - See Note 1
3	Output Seal	1	210737*	
	<b>Output Shaft Bearing Kit</b>	<b>1</b>	<b>513877</b>	<b>Includes items 4-6</b>
4	Snap Ring	1	78937	
5	Bearing Cup	2	131212	
6	Bearing Cone	2	131211	
<b>7</b>	<b>D-Housing Cover Kit</b>	<b>1</b>	<b>513581</b>	<b>Cover # 302576-NSS - D190 only</b>
8	Rear Cover Capscrew - Short	4	131105	55 mm - D190 only
9	Rear Cover Capscrew - Long	8	131375	70 mm - D190 only
10	Fill Plug	1	129492	3/4" magnetic - All Models
10a	Temperature Sensor Plug	1	90898	1/2" magnetic - All Models
11	Rear Cover Nut	2	127567	D190 only
12	Washer - Rear Cover	2	130877	D190 only
13	Stud - Double Ended	2	130903	75 mm - D190 only
14	Drain Plug	1	54254	3/4" magnetic
15	Axle Housing	1		Contact your OEM for specific part number
16	Breather	1	NSS	Order breather kit part number 507162
17	Breather Hose	1	NSS	Order breather kit part number 507162
18	Carrier Capscrew - Long	A/R	131106	carrier to housing (see kits on next page) - 85mm
19	Carrier Capscrew - Short	A/R	131105	Carrier to housing (see kits on next page) - 55 mm
20	Stud - double ended	2	130901	Carrier to housing - 80mm
20a	Stud - double ended	2	132927	Carrier to housing - 80mm
21	Washer	2	130877	Carrier to housing
22	Nut	2	127567	Carrier to housing
23	Spindle Nut - Outer	2	119881	
24	Locking Ring	2	119883	
25	Spindle Nut - Inner	2	119882	
26	Loctite	1	129293	Not illustrated
27	RTV Sealant	1	107276S	Not illustrated

**Note 1:** The 131468 output shaft included a 131355 output shaft washer. This washer is NLA and replaced by none. Shaft p/n 131536 does not use a washer, do not use 131355 with shaft p/n 131536.

### Summary of Kits & Assemblies

Description	Kit Part #	Notes
D-Housing Cover Assembly	513581	D190 series only. Includes items 4, 7, 10, & 10A
U-Tube Breather Kit	507162	Includes items 16 and 17
Output Shaft Kit	512894	Includes items 1 and 2
D-Housing Cover Hardware Kit	513351	Includes items 8-9, 11-12 - D190 only
Axle Housing Hardware Kit - Forward	512896	Includes items 18-22, 26-27
Axle Housing Hardware Kit - Rear	512897	Includes items 18-19, 26-27
Output Shaft Bearing Kit	513877	Includes items 4-6

## Axle Housing Hardware Kit Listing

D-Housing Model: D190			Models: D170, D190			Models: R170, R190, S170, S190		
Dana# 513351			Dana# 512896			Dana# 512897 Note 1		
Qty	P/N	Description	Qty	P/N	Description	Qty	P/N	Description
4	131105	capscrew - 55mm	9	131105	capscrew - 55mm	10	131105	capscrew - 55mm
8	131375	capscrew - 70mm	3	131106	capscrew - 85mm	4	131106	capscrew - 85mm
2	130903	stud - dbl ended	2	130901	stud - dbl ended	1	129293	loctite tube
2	127567	nut	2	127567	nut	1	shais155	information sheet
2	130877	washer	2	130877	washer			
1	129293	loctite tube	1	129293	loctite tube			
1	107276S	rtv tube	1	107276S	rtv tube			
1	shais156	information sheet	1	shais155	information sheet			

**Note 1:** For S170D Models - GM uses 2-131499 capscrews along with 2-130807 washers in place of 2 of the 131106 capscrews. These parts should be purchased separately.

## Axle Shafts

Dana D170 and D190 series axle shafts are used in “sets,” have unequal shaft lengths and may be “location specific” or “Wheel Equipment specific.” When replacing D/R170, D/R190 or S170/190 axle shafts, locate the axle shaft part number (see Model Identification page 4) or select the correct axle shaft from the chart below before placing your order.

DO NOT MISPLACE AXLE SHAFTS FROM THEIR INTENDED LOCATION.

### Axle Shafts - For Standard Models

Model	Part No.	Qty	Spline	Body O.D.	Shaft Length	Spline Length	BC Dim.	Flange O.D.	Flange Holes
<b>D/R170, S170 Axle Shafts</b>									
40-50K	131428	1	46	2.06	37.00	3.70	7.244	8.500	.948-TPR
	131429	1	46	2.06	46.00	3.70	7.244	8.500	.948-TPR
	131804	1	46	2.06	45.15	3.70	7.000	8.500	.773 STR
	131805	1	46	2.06	36.15	3.70	7.000	8.500	.773 STR
<b>D/R190, S190 Axle Shafts</b>									
52-60K	131246	1	46	2.25	37.00	3.70	7.200	8.500	.948-TPR
	131247	1	46	2.25	46.00	3.70	7.244	8.500	.948-TPR

### Axle Shaft - For Diff Lock Models

Model	Part No.	Qty	Spline	Body O.D.	Shaft Length	Spline Length	BC Dim.	Flange O.D.	Flange Holes
<b>D/R170D, S170D Axle Shafts</b>									
40-60K	131245	1	46	2.25	46.00	11.50	7.200	8.500	.948-TPR
	131246	1	46	2.25	37.00	3.70	7.200	8.500	.948-TPR
	131806	1	46	2.25	45.15	11.50	7.000	8.500	.773 STR
	131807	1	46	2.25	36.15	3.70	7.000	8.500	.773 STR
<b>D/R190D, S190D Axle Shafts</b>									
52-60K	131245	1	46	2.25	46.00	11.50	7.000	8.500	.948-TPR
	131246	1	46	2.25	37.00	3.70	7.000	8.500	.948-TPR
	132813	1	46	2.25	47.56	11.70	7.244	8.500	.948-TPR
	132814	1	46	2.25	38.56	3.70	7.244	8.500	.948-TPR

### Axle Shaft - Wide Track Models

Model	Part No.	Qty	Spline	Body O.D.	Shaft Length	Spline Length	Flange O.D.	Flange Holes	OEM
<b>D/R170, D/R190 Axle Shafts</b>									
40-60K	131503	1	46	2.25	48.84	11.50	7.00	8.500	.948-TPR
	131504	1	46	2.25	39.84	3.70	7.00	8.500	.948-TPR

## Yokes & Flanges

To replace the driveline yoke on any of the Dana D170/D190 series, simply order a Spicer Yoke & Slinger Kit from the charts below. Each Yoke Replacement Kit maintains the original part number of the yoke itself for identity purposes, but also includes a new replacement nut along with very important installation instructions and torque figures.

**Style Z  
Half Round  
Tapped Holes  
Bearing Strap**

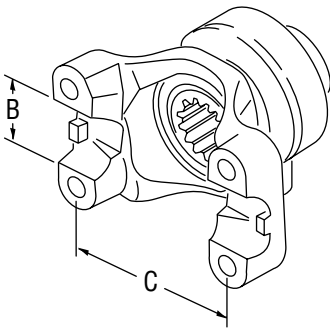

**Style Z  
Half Round  
Tapped Holes  
Bearing Strap**

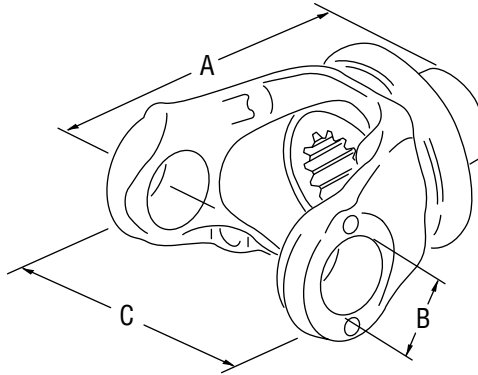

**Style Z  
Half Round  
Tapped Holes  
Bearing Strap**

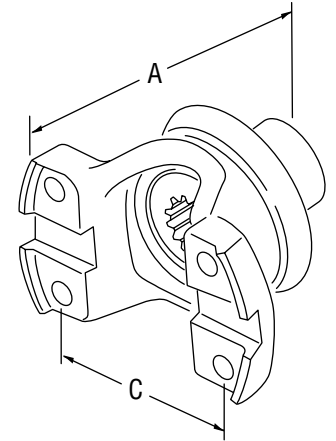

### Input Yoke and Slinger Assembly - 49 Inv Spline

Dana Part Number	Nut Part Number	Series	Joint Angle	Type	Identification P/N
131447K *	131095	1810	30 Deg.	Half Rd.	6-5-4-5101-1
131448K *	131095	1810	30 Deg.	Full Rd.	6-5-4-5101
131446K *	131095	SPL250	25 Deg.	Half Rd.	250-4-1031-1
131520K	131095	1760	30 Deg.	Half Rd.	5005582

### Output Yoke and Slinger Assembly - 41 Inv Spline

Yoke & Slinger	Nut Part Number	Series	Joint Angle	Type	Identification P/N
131449K *	128049	1710	38 Deg.	Full Rd.	6-4-10301
131450K *	128049	1710	39 Deg.	Full Rd.	6-4-10301-1
131451K *	128049	SPL170	45 Deg.	Half Rd.	170-4-1901-1

### Rear Pinion Yoke and Slinger Assembly - 49 Inv Spline

Yoke & Slinger	Nut Part Number	Series	Joint Angle	Type	Identification P/N
131442K *	131095	1710	30 Deg.	Full Rd.	6-4-10291
131439K	131095	1710	45 Deg.	Full Rd.	6-4-10311
131437K *	131095	1710	30 Deg.	Half Rd.	6-4-10291-1
131438K *	131095	1710	45 Deg.	Half Rd.	6-4-10311-1
131441K	131095	1760	30 Deg.	Full Rd.	6-3-4-1861
131440K	131095	1760	30 Deg.	Half Rd.	6-3-4-1861-1
131444K	131095	1810	30 Deg.	Full Rd.	6-5-4-5091
131443K	131095	1810	30 Deg.	Half Rd.	6-5-4-5091-1
131436K	131095	Comp Flg	---	Comp Flg	6-1-6281
131433K *	131095	SPL 170	25 Deg.	Half Rd.	170-4-1891-1
131434K *	131095	SPL 170	45 Deg.	Half Rd.	170-4-1911-1
131435K	131095	SPL 250	25 Deg.	Half Rd.	250-4-1021-1

\* Most popular - Spicer recommends keeping these in stock

## Service Kits

### Seal Driver Kit

#### Part Number 513349

Kit includes: 131471, 131472, 210749

	D-Input	D-Output	R-Pinion
Location			
Tool	<p>210749</p> <p>131472</p>	<p>131471</p>	<p>210749</p> <p>131472</p>

### Wheel Differential Bearing Adjustment Kit

#### Part Number 513061

Kit includes 130971, 130997, 130998, HN115, SHAIS150

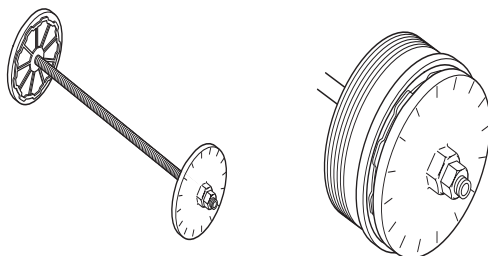

## Bearing Kits

### Forward Tandem Axle Models

Part No. Description	Qty	514011	514238	514012
		D170D	D170S	D190S D190D
Threaded Diff Brg Cup - Plain Half	1	131048	131044	131048
Diff Bearing Cone - Plain Half	1	131042	131041	131042
Threaded Diff Brg Cup - Flange Half	1	131044	131044	131044
Diff Bearing Cone - Flange Half	1	131041	131041	131041
Pinion Pilot Bearing	1	- - -	- - -	129947
Pinion Brg Cone - Inner	1	131050	131050	131050
Pinion Brg Cup - Inner	1	131051	131051	131051
Pinion Brg Cup - Outer	1	131203	131203	131203
Pinion Bearing Cone - Outer	1	131202	131202	131202
Output Side Gear Brg Cup	1	131209	131209	131209
Output Side Gear Brg Cone	1	131208	131208	131208
Input Shaft Brg Cone	1	131205	131205	131205
Input Adjuster Brg Cup	1	131206	131206	131206
Input Shaft Washer	1	131354	131354	131354
V-Ring	1	131333	131333	131333
Oil Seal - Output Shaft	1	210737	210737	210737
Loctite Tube	1	129293	129293	129293
Input Shaft Nut	1	131095	131095	131095
Oil Seal - Input Location	1	131008	131008	131008
Gasket Compound - RTV	1	107276S	107276S	107276S
Information Sheet	1	SHAIS154	SHAIS154	SHAIS154

### Single Axle and Rear-Rear Tandem Models

Part No. Description	Qty	514013	514014	514239	514240	514015	514016
		R170S S170S	R170 S170S	R170D S170D	R170D S170D	R190 S190	R190 S190
		2.69-3.91	4.10-7.17	2.69-3.91	4.10-7.17	2.53-4.78	5.25-7.83
Threaded Diff Brg Cup - Plain Half	1	131044	131044	131048	131048	131048	131048
Diff Bearing Cone - Plain Half	1	131041	131041	131042	131042	131042	131042
Threaded Diff Brg Cup - Flange Half	1	131044	131044	131044	131044	131044	131044
Diff Bearing Cone - Flange Half	1	131041	131041	131041	131041	131041	131041
Pinion Pilot Bearing	1	129947	- - -	129947	- - -	129947	126187
Pinion Brg Cone - Inner	1	131050	131050	131050	131050	131050	131050
Pinion Brg Cup - Inner	1	131051	131051	131051	131051	131051	131051
Pinion Brg Cup - Outer	1	131051	131051	131051	131051	131051	131051
Pinion Bearing Cone - Outer	1	131052	131052	131052	131052	131052	131052
Loctite Tube	1	129293	129293	129293	129293	129293	129293
R-Pinion Nut	1	131095	131095	131095	131095	131095	131095
Oil Seal - R-Pinion	1	131008	131008	131008	131008	131008	131008
Gasket Compound - RTV	1	107276S	107276S	107276S	107276S	107276S	107276S
Information Sheet	1	SHAIS154	SHAIS154	SHAIS154	SHAIS154	SHAIS154	SHAIS154

## Bearing Spacers

When servicing, select a variable pinion bearing spacer from the list below to attain the correct pinion bearing preload. All procedures on "Pinion Bearing Preload" remain the same and the proper steps should be followed according to your Dana Spicer Service Manual.

### D170/D190

Dana P/N	Spacer Thickness	Dana P/N	Spacer Thickness
131376	21.760	*131408	22.360
131377	21.790	*131409	22.375
131378	21.820	131410	22.390
131379	21.850	131411	22.405
131380	21.880	131412	22.420
131381	21.910	131413	22.435
131382	21.940	131414	22.450
131383	21.970	131415	22.465
131384	22.000	131416	22.495
131385	22.015	131417	22.525
131386	22.030	131418	22.555
131387	22.045	131419	22.585
131388	22.060	131420	22.615
131389	22.075	131421	22.645
131390	22.090	131422	22.675
*131391	22.105	131423	22.705
*131392	22.120	132838	21.775
*131393	22.135	132839	21.805
*131394	22.150	132840	21.835
*131395	22.165	132841	21.865
*131396	22.180	132842	21.895
*131397	22.195	132843	21.925
*131398	22.210	132844	21.955
*131399	22.225	132845	21.985
*131400	22.240	132846	22.470
*131401	22.255	132847	22.510
*131402	22.270	132848	22.540
*131403	22.285	132849	22.570
*131404	22.300	132850	22.600
*131405	22.315	132851	22.630
*131406	22.330	132852	22.660
*131407	22.345	132853	22.680

### R170/R190, S170/S190

Dana P/N	Spacer Thickness	Dana P/N	Spacer Thickness
131053	7.750	131074	8.140
132825	7.765	131075	8.155
131054	7.780	131076	8.170
132826	7.795	131077	8.185
131055	7.810	131078	8.200
132827	7.825	131079	8.215
*131056	7.840	131080	8.230
*132828	7.855	131081	8.245
*131057	7.870	131082	8.260
*132829	7.885	132830	8.275
*131058	7.900	131083	8.290
*131059	7.915	132831	8.305
*131060	7.930	131084	8.320
*131061	7.945	132832	8.335
*131062	7.960	131085	8.350
*131063	7.975	132833	8.365
*131064	7.990	132834	8.395
*131065	8.005	131086	8.380
*131066	8.020	131087	8.410
*131067	8.035	132835	8.425
*131068	8.050	131088	8.440
*131069	8.065	132836	8.455
*131070	8.080	132837	8.485
*131071	8.095	131089	8.470
*131072	8.110	131090	8.500
131073	8.125		

\* Most popular - Spicer recommends keeping these in stock



## D170(P) - Forward Rear with Pump

18" Ring Gear Diameter  
Side Gear # 300GD101

These new carrier units directly replace tandem forward models D40-170(P), D46-170(P), and D46-170H(P) with no modifications.

Ratio	Side Gear Spline	Non-Pump New Carrier	Pump New Carrier
3.07	46 Involute	681000	681034
3.21	46 Involute	681001	681035
3.31	46 Involute	681002	681036
3.42	46 Involute	681003	681037
3.58	46 Involute	681004	681038
3.73	46 Involute	681005	681039
3.91	46 Involute	681006	681040
4.10	46 Involute	681007	681041
4.30	46 Involute	681008	681042
4.56	46 Involute	681009	681043
4.78	46 Involute	681010	681044
5.25	46 Involute	681011	681045
5.38	46 Involute	681012	681046
5.57	46 Involute	681013	681047
6.14	46 Involute	681014	681048
6.83	46 Involute	681015	681049
7.17	46 Involute	681016	681050

## R170 - Rear Rear

18" Ring Gear Diameter  
Side Gear #300GD101

**Note:** Drive Axle Tag may read R46-170, S23-170

These new carrier units directly replace tandem rear-rear models R40-170, R46-170, and single axle models S21-170, S23-170, and S26-170 with no modifications.

Ratio	Side Gear Spline	New Carrier	Notes
2.69	46 Involute	681180	Note 1
2.87	46 Involute	681181	Note 1
2.93	46 Involute	681182	Note 1
3.07	46 Involute	681183	
3.21	46 Involute	681184	
3.31	46 Involute	681185	
3.42	46 Involute	681186	
3.58	46 Involute	681187	
3.73	46 Involute	681188	
3.91	46 Involute	681189	
4.10	46 Involute	681190	
4.30	46 Involute	681191	
4.56	46 Involute	681192	
4.78	46 Involute	681193	
5.25	46 Involute	681194	
5.38	46 Involute	681252	
5.57	46 Involute	681253	
6.14	46 Involute	681254	
6.83	46 Involute	681255	
7.17	46 Involute	681256	

**Note 1:** Single axle applications only.

### D170D(P) - Forward Rear with Diff Lock & Pump

18" Ring Gear Diameter  
Side Gear # 300GD101

These new carrier units will directly replace tandem forward models D40-170D(P), D46-170D(P), and D46-170DH(P) with no modifications.

Ratio	Side Gear Spline	Diff Lock New Carrier	Diff Lock w/Pump New Carrier
3.07	46 Involute	681017	681051
3.21	46 Involute	681018	681052
3.31	46 Involute	681019	681053
3.42	46 Involute	681020	681054
3.58	46 Involute	681021	681055
3.73	46 Involute	681022	681056
3.91	46 Involute	681023	681057
4.10	46 Involute	681024	681058
4.30	46 Involute	681025	681059
4.56	46 Involute	681026	681060
4.78	46 Involute	681027	681061
5.25	46 Involute	681028	681062
5.38	46 Involute	681029	681063
5.63	46 Involute	681030	681064
6.14	46 Involute	681031	681065
6.83	46 Involute	681032	681066
7.17	46 Involute	681033	681067

### R170D - Rear Rear with Diff Lock

18" Ring Gear Diameter  
Side Gear # 300GD101

**Note:** Drive Axle Tag may read R46-170D or S23-170D

These new carrier units directly replace tandem rear-rear models R40-170D, R46-170D, and single axle models S21-170D and S23-170D with no modifications.

Ratio	Side Gear Spline	Diff Lock New Carrier	Notes
2.69	46 Involute	681195	Note 1
2.87	46 Involute	681196	Note 1
2.93	46 Involute	681197	Note 1
3.07	46 Involute	681198	
3.21	46 Involute	681199	
3.31	46 Involute	681200	
3.42	46 Involute	681201	
3.58	46 Involute	681202	
3.73	46 Involute	681203	
3.91	46 Involute	681204	
4.10	46 Involute	681205	
4.30	46 Involute	681206	
4.56	46 Involute	681207	
4.78	46 Involute	681208	
5.25	46 Involute	681209	
5.38	46 Involute	681257	
5.57	46 Involute	681258	
6.14	46 Involute	681259	
6.83	46 Involute	681260	
7.17	46 Involute	681261	

**Note 1:** Single axle applications only.

## D190 - Forward Rear

### 18.50" Ring Gear Diameter Side Gear # 300GD101

These new carrier units will directly replace tandem forward models D52-190, and D60-190 with no modifications. See Note 1.

Ratio	Side Gear Spline	New Carrier	Notes
3.42	46 Involute	681068	
3.58	46 Involute	681069	
3.73	46 Involute	681070	
3.91	46 Involute	681071	
4.10	46 Involute	681072	
4.30	46 Involute	681073	
4.56	46 Involute	681074	
4.78	46 Involute	681075	
5.25	46 Involute	681076	
5.38	46 Involute	681077	
5.57	46 Involute	681078	
6.14	46 Involute	681079	
6.83	46 Involute	681080	
7.17	46 Involute	681081	

**NOTE 1:** Dana D190 Forward models come standard with lube pump. Serial tags for production axles may not carry the traditional "P" designation in the model identifier.

## R190 - Rear Rear

### 18.50" Ring Gear Diameter Side Gear # 300GD101

**Note:** Drive Axle Tag may read R46-190 or S23-190

These new carrier units will directly replace tandem rear rear models R46-190, R52-190, and single axle models S23-190, S26-190, and S30-190 with no modifications.

Ratio	Side Gear Spline	New Carrier	Notes
2.53	46 Involute	681288	Note 2
2.69	46 Involute	681210	Note 2
2.87	46 Involute	681211	Note 2
2.93	46 Involute	681212	Note 2
3.07	46 Involute	681213	Note 2
3.21	46 Involute	681214	Note 2
3.31	46 Involute	681215	Note 2
3.42	46 Involute	681216	
3.58	46 Involute	681217	
3.73	46 Involute	681218	
3.91	46 Involute	681219	
4.10	46 Involute	681220	
4.30	46 Involute	681221	
4.56	46 Involute	681222	
4.78	46 Involute	681223	
5.25	46 Involute	681224	
5.38	46 Involute	681225	
5.57	46 Involute	681226	
6.14	46 Involute	681227	
6.83	46 Involute	681228	
7.17	46 Involute	681229	
7.83	46 Involute	681230	Note 2

**Note 2:** Single Axle applications only.

## D190D - Forward Rear w/ Diff Lock

18.50" Ring Gear Diameter  
Side Gear # 300GD101

These new carrier units will directly replace tandem forward models D52-190D with no modifications. See Note 1.

Ratio	Side Gear Spline	Diff Lock New Carrier	Notes
3.42	46 Involute	681082	
3.58	46 Involute	681083	
3.73	46 Involute	681084	
3.91	46 Involute	681085	
4.10	46 Involute	681086	
4.30	46 Involute	681087	
4.56	46 Involute	681088	
4.78	46 Involute	681089	
5.25	46 Involute	681090	
5.38	46 Involute	681091	
5.57	46 Involute	681092	
6.14	46 Involute	681093	
6.83	46 Involute	681094	
7.17	46 Involute	681095	

## R190D - Rear Rear w/ Diff Lock

18.50" Ring Gear Diameter  
Side Gear #300GD101

**Note:** Drive Axle Tag may read R46-190D or S23-190D

These new carrier units will directly replace tandem forward models R46-190D, R52-190D, and single axle models S23-190D, S26-190D, and S30-190D with no modifications.

Ratio	Side Gear Spline	Diff Lock New Carrier	Notes
2.53		N/A	Not Released
2.69	46 Involute	681231	Note 2
2.87	46 Involute	681232	Note 2
2.93	46 Involute	681233	Note 2
3.07	46 Involute	681234	Note 2
3.21	46 Involute	681235	Note 2
3.31	46 Involute	681236	Note 2
3.42	46 Involute	681237	
3.58	46 Involute	681238	
3.73	46 Involute	681239	
3.91	46 Involute	681240	
4.10	46 Involute	681241	
4.30	46 Involute	681242	
4.56	46 Involute	681243	
4.78	46 Involute	681244	
5.25	46 Involute	681245	
5.38	46 Involute	681246	
5.57	46 Involute	681247	
6.14	46 Involute	681248	
6.83	46 Involute	681249	
7.17	46 Involute	681250	
7.83	46 Involute	681251	

**NOTE 1:** Dana D190D Forward models with Diff Lock come standard with lube pump. Serial tags for production axles may not carry the traditional "P" designation in the model identifier.

**Note 2:** Single Axle applications only.

## Spicer Service Kits Parts Listing

(Listed in numerical order)

Dana P/N	Description	Notes
131008K	PINION SEAL & NUT KIT	ONLY D-INPUT & REAR-PINION MODELS
131095K	PINION NUT KIT	ONLY D-INPUT & REAR-PINION MODELS
131339	IAD ASSEMBLY	ALL MODELS
131345	HELICAL GEAR & BUSHING ASSY	ALL D170, 190 MODELS
507162	U-TUBE BREATHER KIT	ALL MODELS
510870	SHIFT FORK & SPRING KIT	ALL D170 MODELS
512892	AIR LOCKOUT REPAIR KIT	ALL D170, 190 MODELS
512893	AIR LOCKOUT REPAIR KIT - COMPLETE W/ FORK	D170 MODELS ONLY
512894	OUTPUT SHAFT KIT	ALL D170, 190 MODELS
512895	DIFF LOCK REPAIR KIT	ALL DIFF LOCK MODELS
512896	AXLE HSG HARDWARE KIT - FORWARD AXLE	ALL D170, 190 MODELS
512897	AXLE HSG HARDWARE KIT - REAR AXLE	ALL R170/R190, S170, S190
512946	DIFF LOCK CONVERSION PARTS KIT (3.07, 3.21, 3.91-7.17)	ONLY D/R190D, S190D
512947	DIFF LOCK CONVERSION PARTS KIT (2.53-2.93, 3.31-3.73)	ONLY D/R190D, S190D
513061	WHEEL DIFF BEARING ADJUSTMENT TOOL KIT	ALL MODELS
513349	SEAL DRIVER KIT	ALL MODELS
513351	D-HSG & COVER HARDWARE KIT	ONLY D190 MODELS
513581	AXLE HSG COVER KIT	ONLY D190 MODELS
513839	INPUT SHAFT KIT - NON PUMP MODELS	ONLY D170 MODELS
513840	INPUT SHAFT KIT - PUMP MODELS	ALL D170(P) AND ALL D190 MODELS
513868	WHEEL DIFF KIT-46INV	ALL MODELS
513876	LUBE PUMP PARTS KIT	ALL D170P AND ALL D190 MODELS
513877	OUTPUT SHAFT BRG KIT	ALL D170, 190 MODELS
513878	MANIFOLD PARTS KIT - PUMP MODELS	ALL D170P AND ALL D190 MODELS
513879	INPUT COVER KIT - D190	ONLY D190 MODELS
513880	MANIFOLD PARTS KIT - NON PUMP MODELS	ONLY D170 NON PUMP MODELS
513881	INPUT COVER KIT - D170	ALL D170 MODELS
513997	CARRIER/CAP KIT	D170
513998	CARRIER/CAP KIT	D170D - DIFF LOCK MODELS
513999	CARRIER/CAP KIT	R170, S170
514000	CARRIER/CAP KIT	R170D, S170D DIFF LOCK MODELS
514001	CARRIER/CAP KIT	D190, D190D DIFF LOCK MODELS
514002	CARRIER/CAP KIT	R190, R190D, S190D DIFF LOCK MODELS
514011	BRG KIT - D170D	FOR DIFF LOCK MODELS ONLY
514012	BRD KIT - D190	ALL D190 MODELS
514013	BRG KIT - R170S, S170S	2.69-3.91 RATIOS ONLY
514014	BRG KIT - R170S, S171S	4.10-7.17 RATIOS ONLY
514015	BRG KIT - R190, S190S/D	2.53-4.78 RATIOS ONLY
514016	BRG KIT - R190, S190S/D	5.25-7.83 RATIOS ONLY
514142	SHIFT FORK & SPRING KIT	ALL D190 MODELS
514238	BRG KIT - D170S	ALL RATIOS
514239	BRG KIT - R170D, S170D	2.69-3.91 RATIOS ONLY
514240	BRG KIT - R170D, S170D	4.10-7.17 RATIOS ONLY

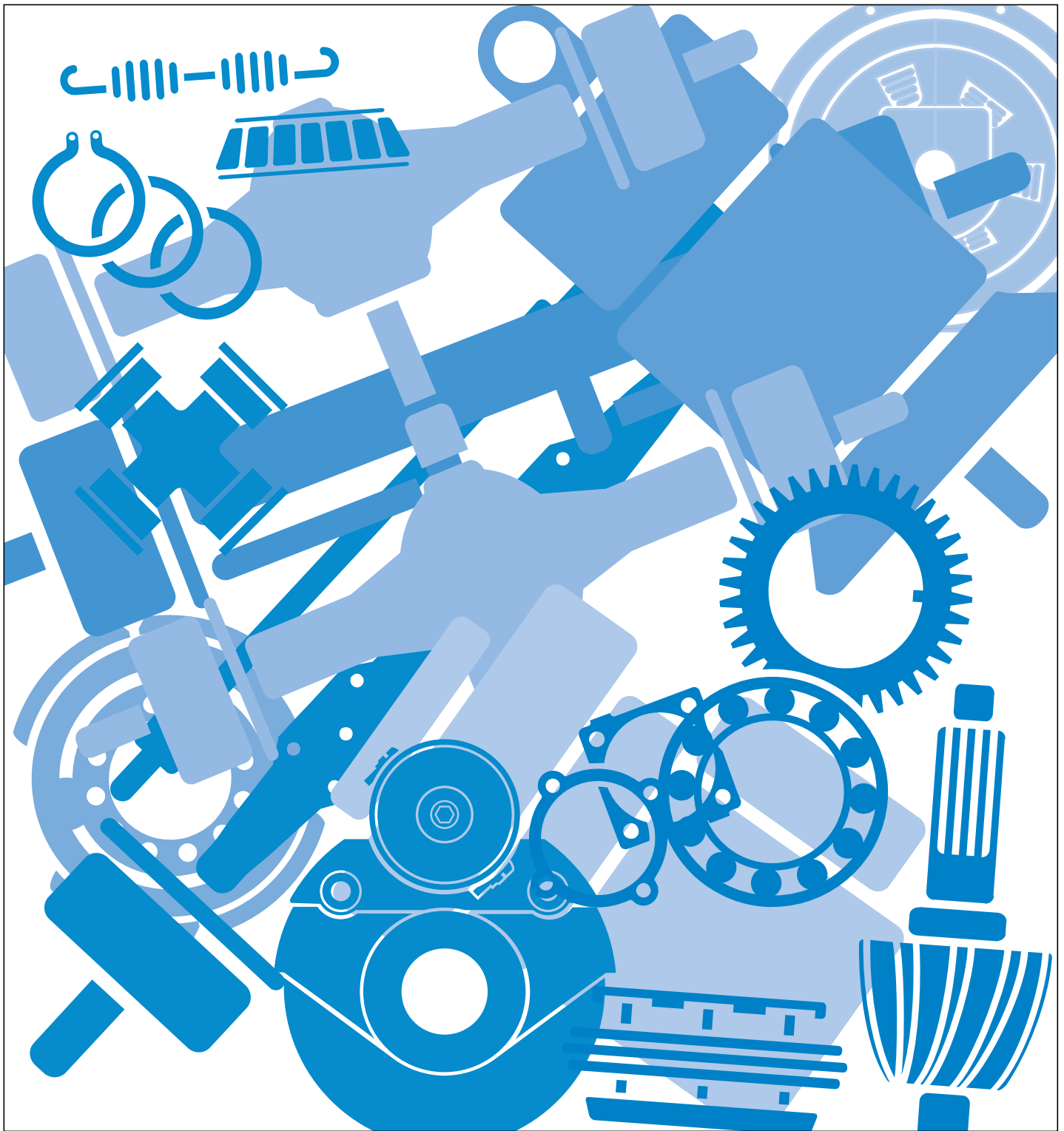

Copyright Eaton and Dana Corporation, 2004. EATON AND DANA CORPORATION hereby grants its customers, vendors, or distributors permission to freely copy, reproduce and/or distribute this document in printed format. THIS INFORMATION IS NOT INTENDED FOR SALE OR RE-SALE, AND THIS NOTICE MUST



National Institute for  
**AUTOMOTIVE  
SERVICE  
EXCELLENCE**

## Roadranger®

**MORE TIME ON THE ROAD**

The Roadranger® System is an unbeatable combination of the best products from Eaton and Dana – partnering to provide you the most advanced, most trouble-free drivetrain in the industry. And it's backed by the Roadrangers – the most experienced, most expert, most accessible drivetrain consultants in the business. Visit our web site at [www.roadranger.com](http://www.roadranger.com). For spec'ing or service assistance, call 1-800-826-HELP (4357) 24 hours a day, 7 days a week, (Mexico: 01-800-826-HELP (4357)) for more time on the road.



**EAT•N**

One Great Drivetrain from Two Great Companies

AXIP-0057  
Printed in USA